

シリコンNPNエビタキシャルプレーナ型トランジスタ (2SA1295とコンプリメンタリ)

用途：オーディオ、一般用

絶対最大定格 (Ta=25 )

記号	規格値	単位
VcBO	230	V
VCEO	230	V
VEBO	5	V
Ic	17	A
Ib	5	A
Pc	200(Tc=25 )	W
Tj	150	
Tstg	-55 ~ +150	

電気的特性 (Ta=25 )

記号	試験条件	規格値	単位
IcBO	Vcb = 230V	100max	μA
IEBO	VEB = 5V	100max	μA
V(BR)CEO	Ic = 25mA	230min	V
hFE	VCE = 4V, Ic = 5V	50min	
VCE(sat)	Ic = 5A, Ib = 0.5A	2.0max	V
fr	VCE = 12V, IE = -2A	60typ	MHz
COB	Vcb = 10V, f = 1MHz	250typ	pF

ランク O(50~100), Y(70~140)

外形図 MT-200

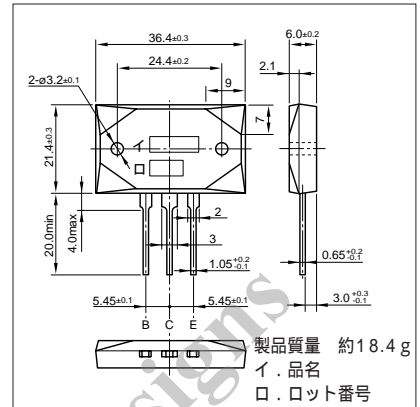

代表的スイッチング特性 (エミッタ接地)

Vcc (V)	RL (Ω)	Ic (A)	VBB1 (V)	VBB2 (V)	Ib1 (A)	Ib2 (A)	ton (μs)	tstg (μs)	tf (μs)
60	12	5	10	-5	0.5	-0.5	0.30typ	2.40typ	0.50typ

Ic-VCE特性 (代表例)

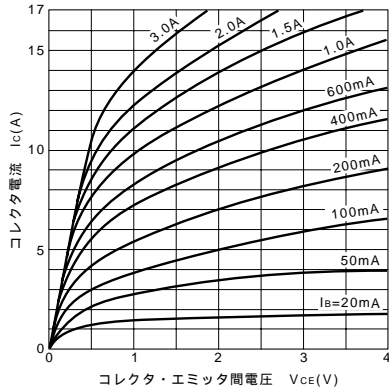

VCE(sat)-Ib特性 (代表例)

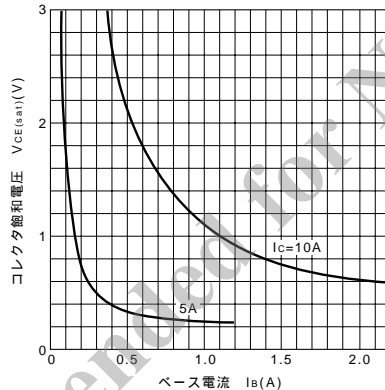

Ic-VBE温度特性 (代表例)

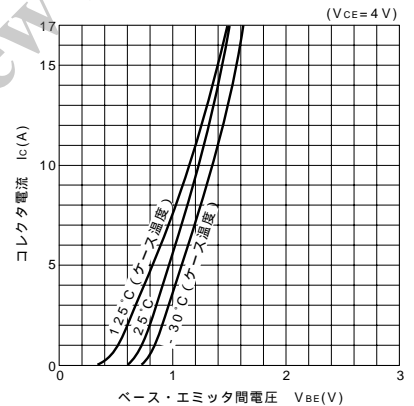

hFE-Ic特性 (代表例)

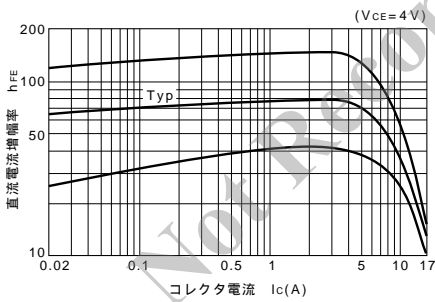

hFE-Ic温度特性 (代表例)

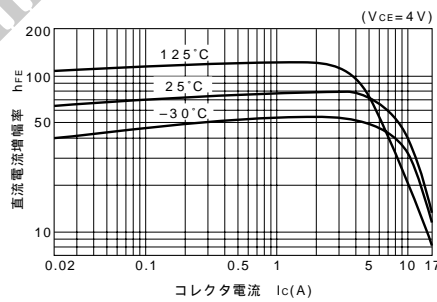

θja-t特性

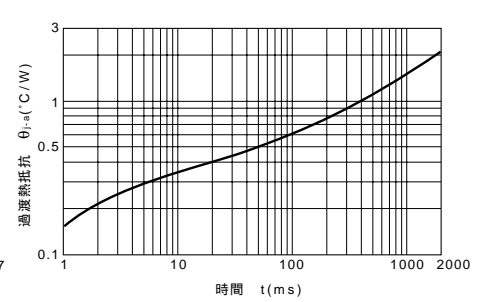

fT-IE特性 (代表例)

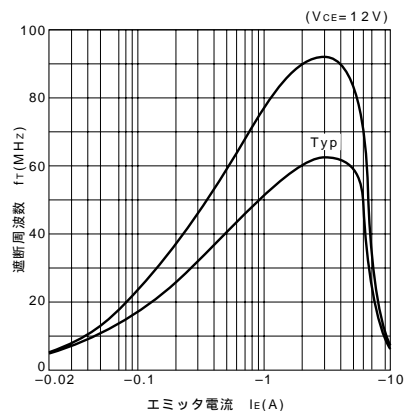

ASO曲線 (単発パルス)

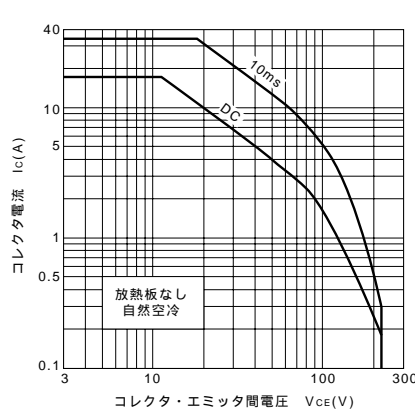

Pc-Ta定格

