

## *C Series C650*

### *650 W Five Module Multi-Output Power Supply*

### General Description

The C Series are flexible multi-output power supplies that enable simple combination of various modules.

### Features and Benefits

- High reliability with low noise and low leakage current
- Medical and information equipment approval to UL60950-1, C-UL, EN60950 and EN60601-1 3rd
- Higher withstand voltage and lower leakage current
- OCP, OVP and OHP, remote sensing, control, and alarm (AC power fail, fan alarm, and low output)

### Table of Contents

Test Circuit	1
Figures	3
Tables	8
Important Information	10

### Sample Test Conditions

#### Input Voltage, $V_{IN}$

Min. (V)	Nom. (V)		Max. (V)
85	100	240	264

#### Load Current, $I_{LOAD}$

Min. (A)	Nom. (A)	Max. (A)
-	-	-

### Sample Test Circuit Diagram

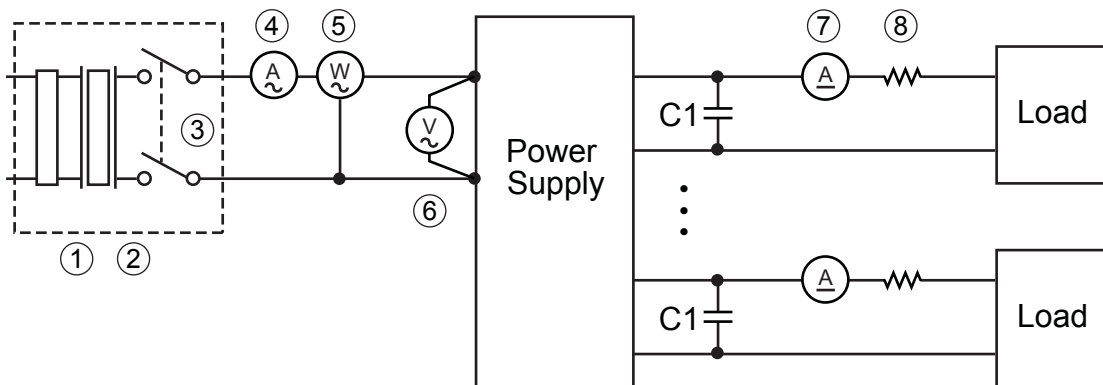

Key	Description	Remarks
-	Measuring instrument	Output voltage is measured with a digital multimeter
1	Variable autotransformer	-
2	Isolation transformer	-
3	Circuit breaker	-
4	Ammeter	-
5	Watt meter	-
6	Volt meter	-
7	Ammeter	-
8	Shunt resistor	-
C1	Load capacitor	Electrolytic capacitor: 47 $\mu$ F Film capacitor: 0.1 $\mu$ F

## List of Figures

---

<b>1. Input Current</b>	<b>3</b>	<b>6. Leakage Current</b>	<b>5</b>
<b>2. Power Factor</b>	<b>3</b>	<b>7. Start-Up Time</b>	<b>6</b>
<b>3. Efficiency</b>	<b>4</b>	<b>8. Hold-Up Time</b>	<b>6</b>
<b>4. Inrush Current</b>	<b>4</b>	<b>9. Conduction Noise 100 V/600 W</b>	<b>7</b>
<b>5. Inrush Current</b>	<b>5</b>	<b>10. Conduction Noise 240 V/650 W</b>	<b>7</b>

## List of Tables

---

<b>1. Input Characteristics</b>	<b>8</b>	<b>3. Noise Tolerance Characteristics</b>	<b>8</b>
Input Current		AC Line Noise	
Input Power		Lightning Surge	
Power Factor		Electrostatic Discharge	
Efficiency		<b>4. Other Characteristics</b>	<b>9</b>
Inrush Current		Withstand Voltage	
Leakage Current		Leakage Current at Withstand Voltage	
Hold-Up Time		Insulation Resistance	
<b>2. Environment Tests</b>	<b>8</b>		
Vibration (Non-Operating)			
Power-On at High Temperature			
Power-On at Low Temperature			
Shock			

## Figures

**Figure 1. Input Current  
(By Load Current)**

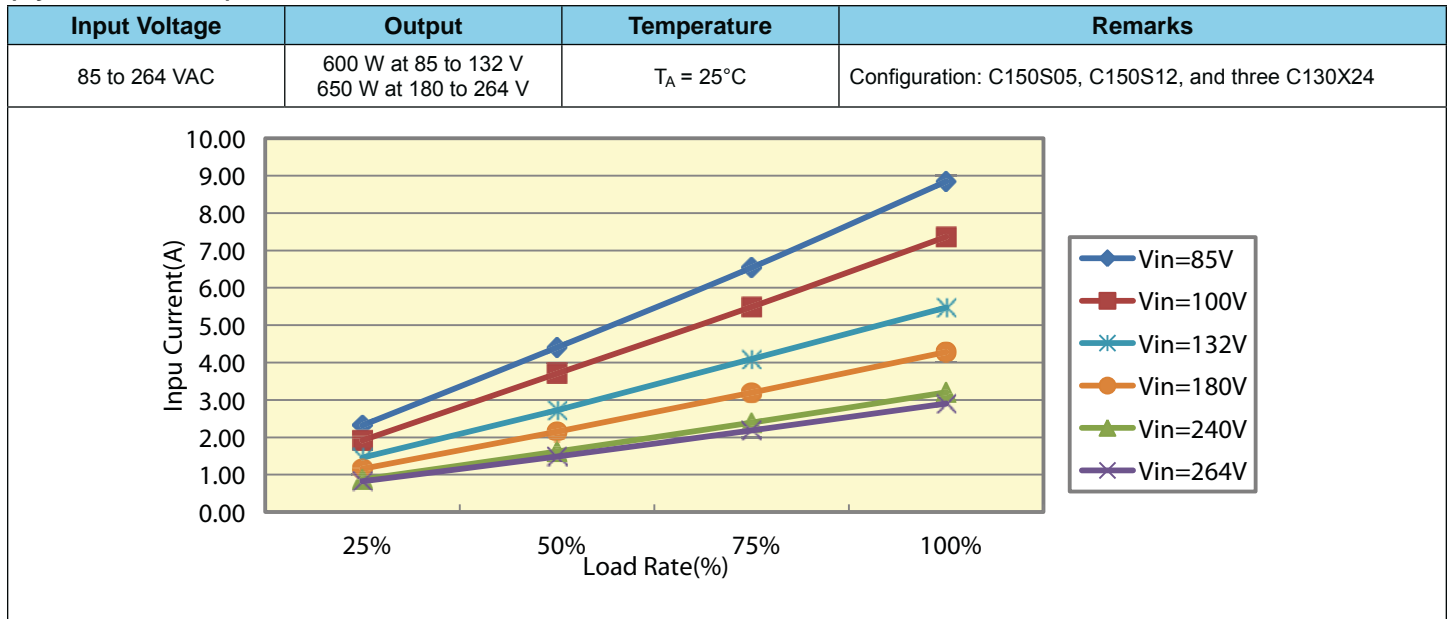

**Figure 2. Power Factor  
(By Load Current)**

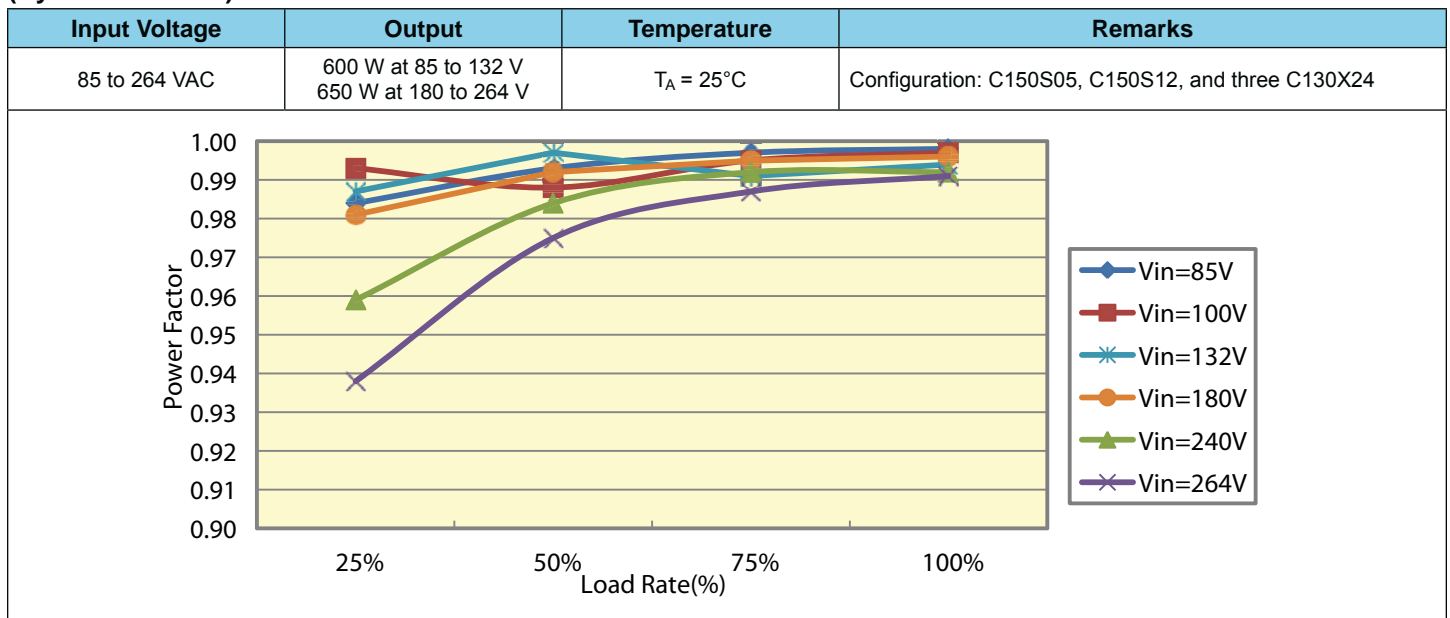

**Figure 3. Efficiency (By Load Current)**

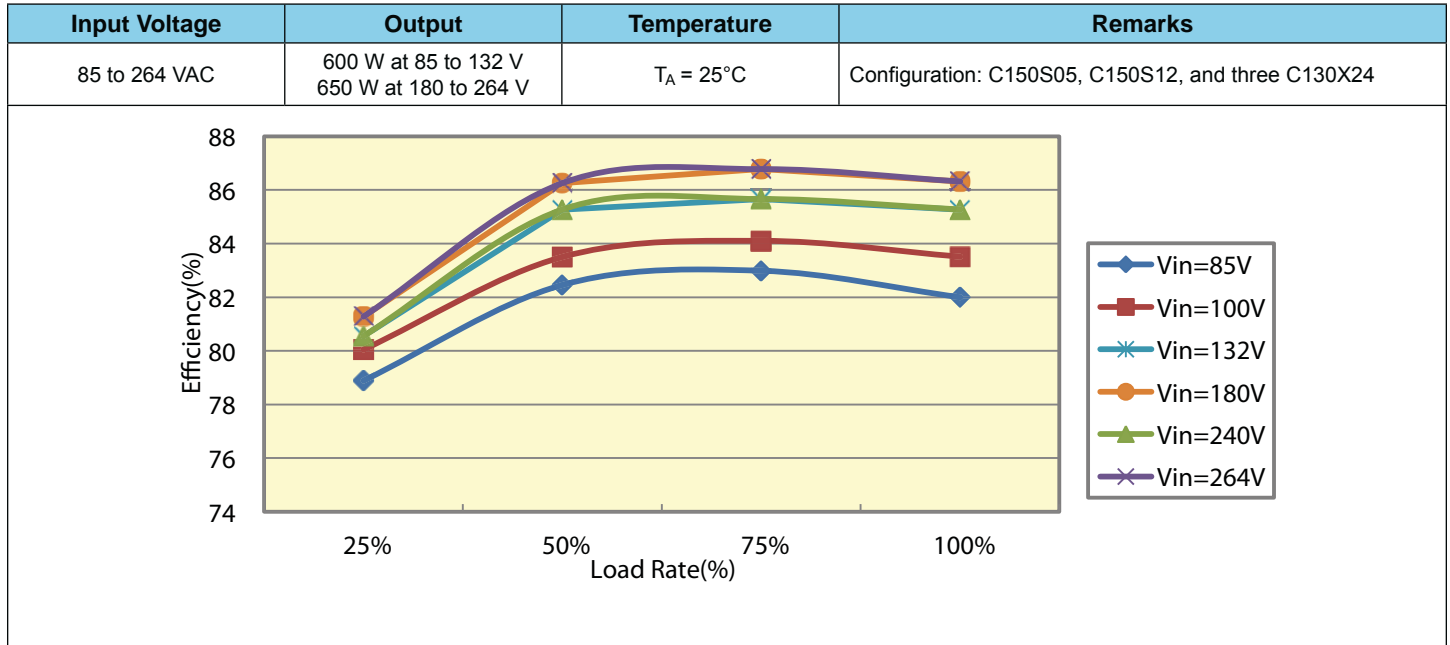

**Figure 4. Inrush Current (By Input Voltage)**

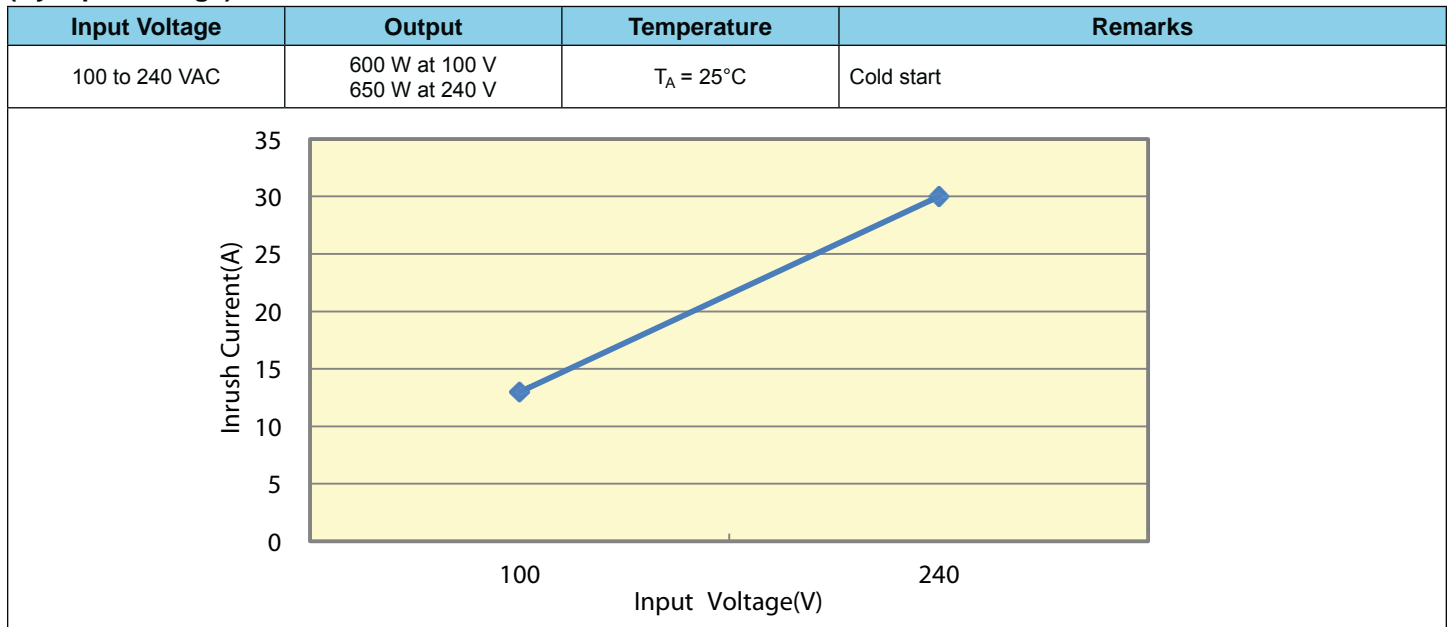

Figure 5. Inrush Current

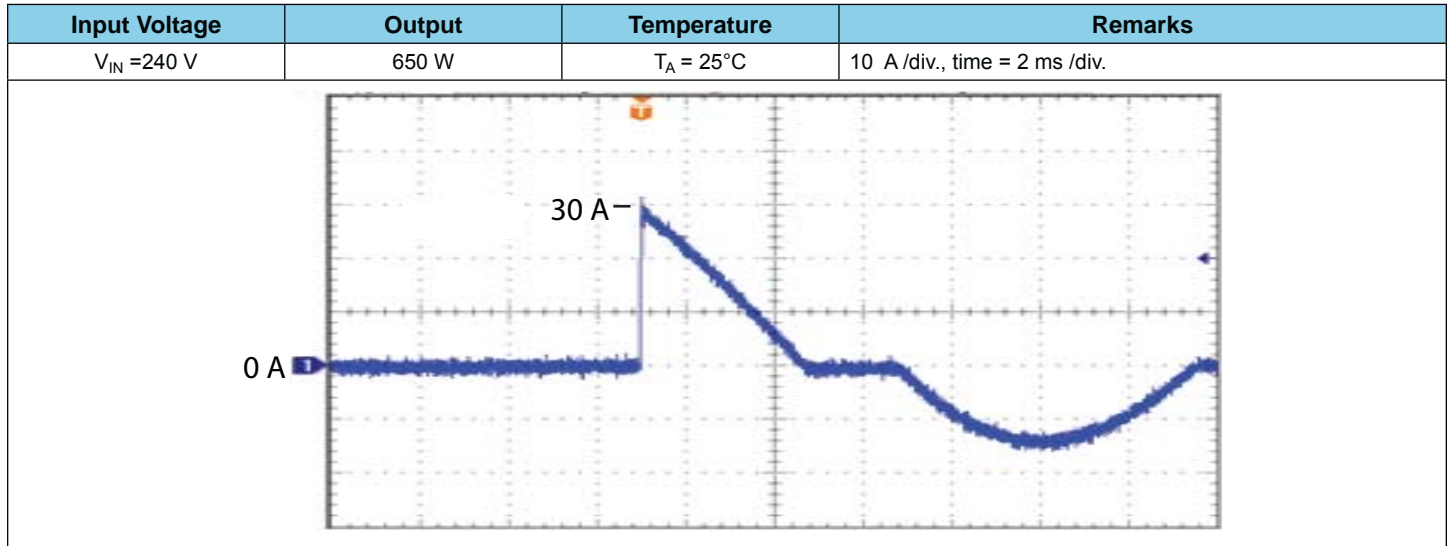
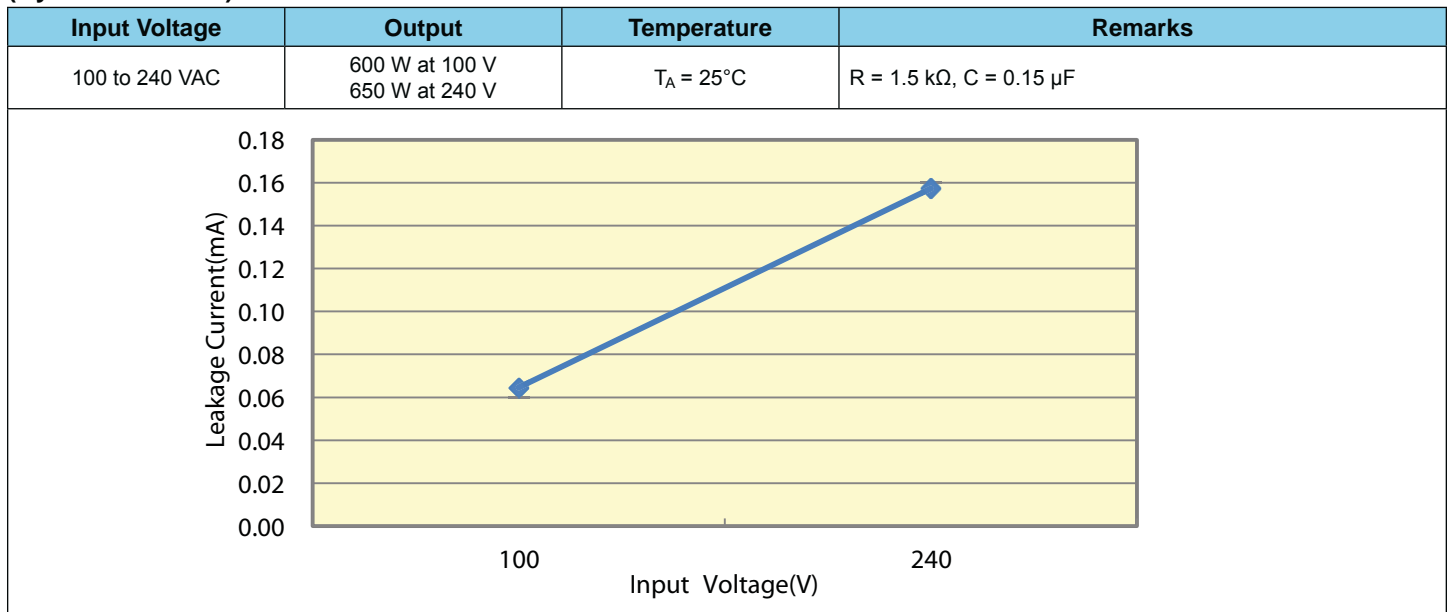
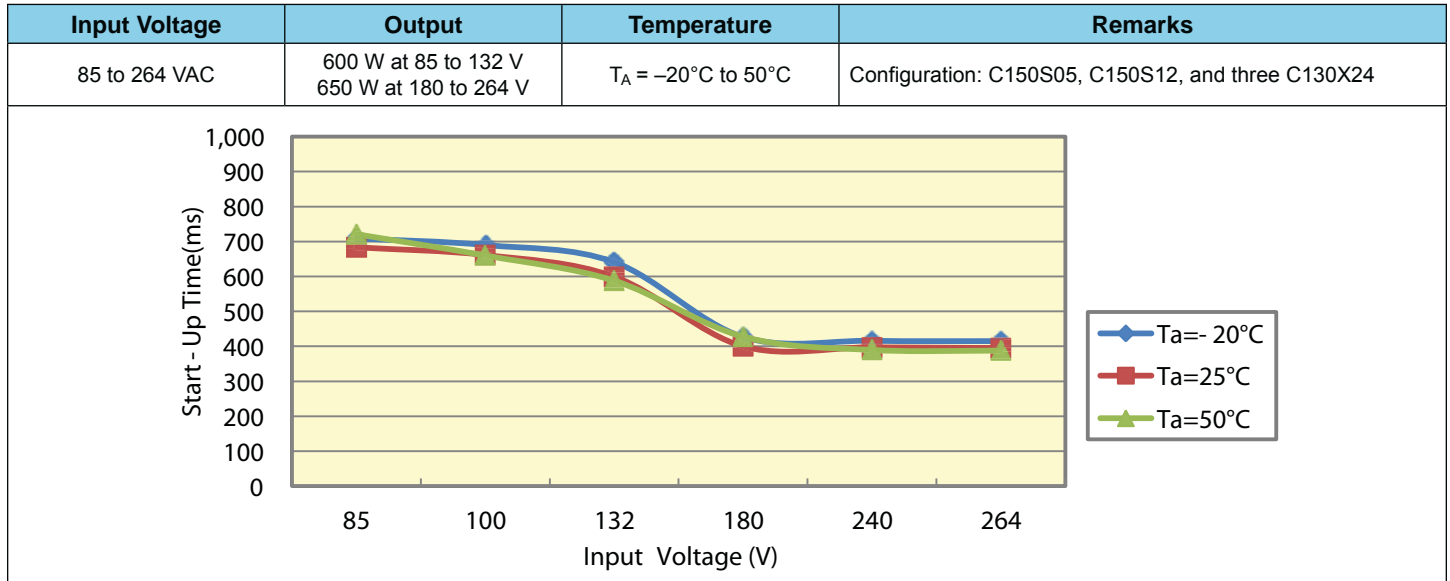

Figure 6. Leakage Current (By Load Current)



**Figure 7. Start-Up Time (By Input Voltage)**



**Figure 8. Hold-Up Time (By Load Rate)**

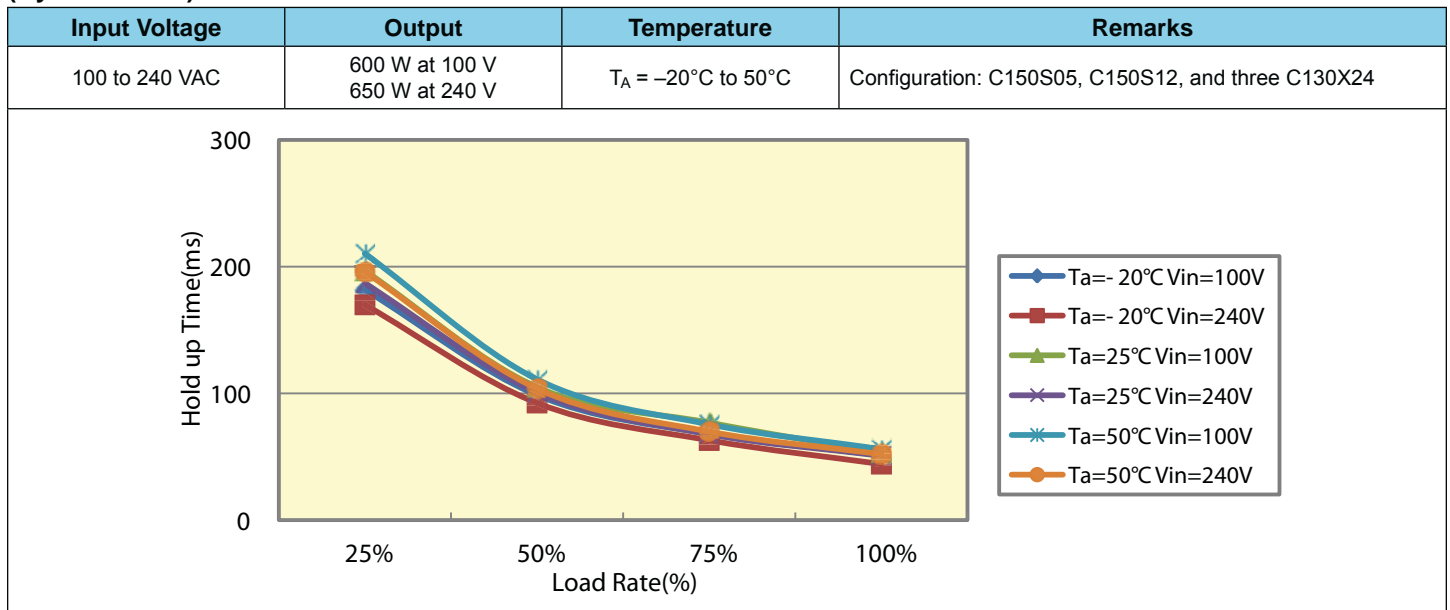

Figure 9. Conduction Noise 100 V/600 W

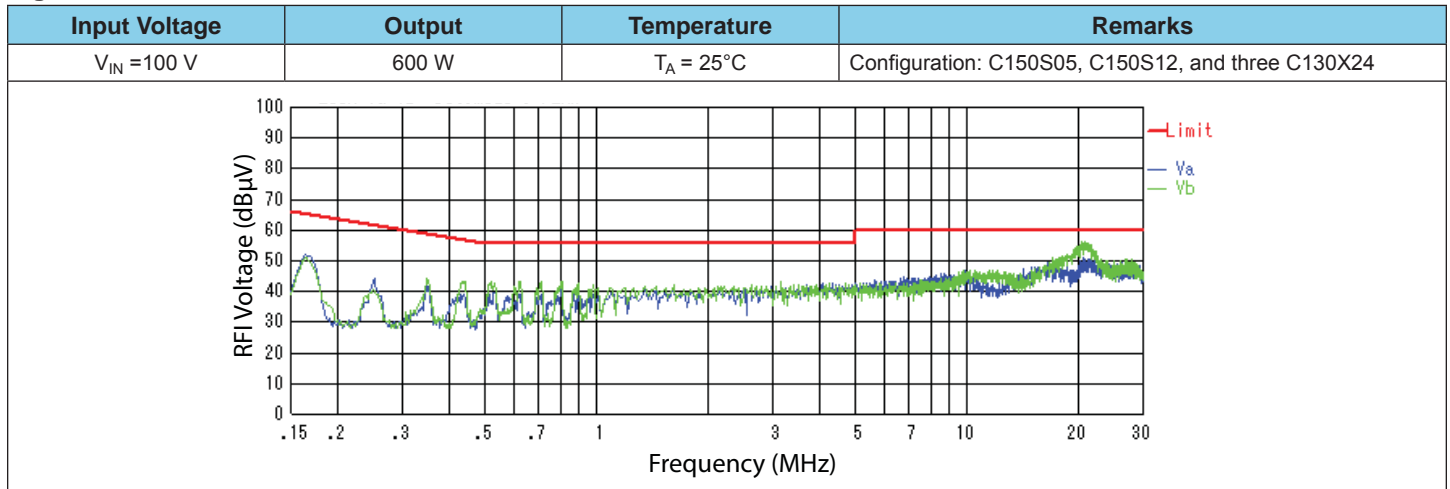
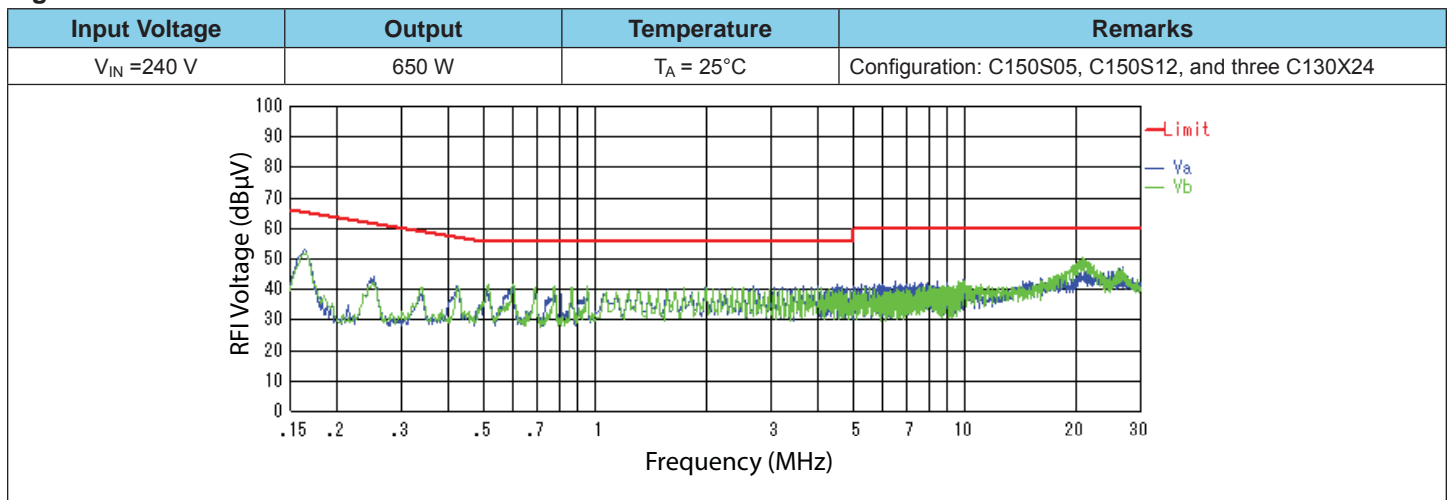

Figure 10. Conduction Noise 240 V/650 W



## Tables

**Table 1. Input Characteristics**  
(At  $T_A = 25^\circ\text{C}$ )

Test Item	Conditions		Test Results			Specification	Remarks
	$V_{IN}$	$I_{LOAD}$	$V_{IN} = 100\text{ V}$	$V_{IN} = 240\text{ V}$			
Input Current	Nom	Nom	7.4 A	3.2 A	–	8.0 A/ 4.0 A	Figure 1
Input Power	Nom	Nom	736.1 W	767.8 W	–	–	–
Power Factor	Nom	Nom	0.997	0.992	–	–	Figure 2
Efficiency	Nom	Nom	83.51%	86.83%	–	–	Figure 3
Inrush Current	Nom	Nom	13.0 A	30.0 A	–	20 A/ 40 A	Figure 4
Leakage Current	Nom	Nom	0.06 mA	0.16 mA	R = 1.5 k $\Omega$ , C = 0.15 $\mu\text{F}$	0.30 mA/ 0.50 mA	Figure 6
Hold-Up Time	–	Nom	–	–	53 ms at $T_A = 25^\circ\text{C}$	10 ms	Figure 8

**Table 2. Environment Tests**  
(At  $T_A = 25^\circ\text{C}$ )

Test Item	Conditions		Test Results	Specification	Remarks
	$V_{IN}$	$I_{LOAD}$			
Vibration (Non-Operating)	–	–	Frequency = 10 to 55 Hz, Sweep Cycle = 3 minutes, Acceleration = 19.6 m/s <sup>2</sup> , Direction = x,y, and z axes at 60 minutes per axis	Normal operation	–
Power-On at High Temperature	Nom	Max	Power-off for 1 hour at 65°C, then power-on	Normal operation	–
Power-On at Low Temperature	Nom	Max	Power-off for 1 hour at –15°C, then power-on	Normal operation	–
Shock	–	–	Product is dropped from a height of 50 mm (98 m/s <sup>2</sup> ) onto a flat surface of wood (10 mm or thicker); the test is performed three times on each edge of the bottom side of the product	Normal operation	–

**Table 3. Noise Tolerance Characteristics**  
(At  $T_A = 25^\circ\text{C}$ )

Test Item	Conditions		Test Results	Specification	Remarks
	$V_{IN}$	$I_{LOAD}$			
AC Line Noise (50 to 1000 ns)	Min to Max	Min to Max	Line to Line $\pm 3.0\text{ kV OK}$	L–L 2.0 kV	–
	Min to Max	Min to Max	Line to Frame Ground $\pm 2.1\text{ kV OK}$	L–FG 2.0 kV	–
Lightning Surge (1.2 $\times$ 50 $\mu\text{s}$ )	Nom	Min to Max	Line to Line $\pm 2.4\text{ kV OK}$	L–L 2.0 kV	–
	Nom	Min to Max	Line to Frame Ground $\pm 2.4\text{ kV OK}$	L–FG 2.0 kV	–
Electrostatic Discharge	Min to Max	Min to Max	$\pm 8.4\text{ kV OK}$ at R = 330 $\Omega$ , C = 150 pF	6.0 kV	–



**Table 4. Other Characteristics**  
(At  $T_A = 25^\circ \text{C}$ )

Test Item	Conditions		Test Results			Specification	Remarks
	$V_{IN}$	$I_{LOAD}$	P-S	P-E	S-E		
Withstand Voltage	-	-	4.0 kV	2.4 kV	0.6 kV	P-S: 4.0 kV for 1 minute P-E: 2.0 kV for 1 minute 2.4 kV for 1 second S-E: 500 V for 1 minute 600 V for 1 second	-
Leakage Current at Withstand Voltage	-	-	3.12 mA	2.58 mA	1.13 mA	$\leq 15 \text{ mA}$	-
Insulation Resistance	-	-	$\geq 1000 \text{ M}\Omega$	$\geq 1000 \text{ M}\Omega$	$\geq 1000 \text{ M}\Omega$	$\geq 100 \text{ M}\Omega$ at 500 VDC Megger	-

## Important Information



- The products described in this document are built-in type DC stabilized power supplies with special structures and are designed for installation in equipment. Be sure to use the products only for installation in equipment.
- The products should be handled only by persons who have competent electrical knowledge.
- Be sure to read through all safety precaution and operation manuals before installation, operation, or maintenance and to use the products only for the intended use and in accordance with all applicable safety standards and regulations in the location of use.

---

Sanken reserves the right to make, from time to time, such departures from the detail specifications as may be required to permit improvements in the performance, reliability, or manufacturability of its products. Therefore, the user is cautioned to verify that the information in this publication is current before placing any order.

When using the products described herein, the applicability and suitability of such products for the intended purpose shall be reviewed at the users responsibility.

Although Sanken undertakes to enhance the quality and reliability of its products, the occurrence of failure and defect of semiconductor products at a certain rate is inevitable.

Users of Sanken products are requested to take, at their own risk, preventative measures including safety design of the equipment or systems against any possible injury, death, fires or damages to society due to device failure or malfunction.

Sanken products listed in this publication are designed and intended for use as components in general-purpose electronic equipment or apparatus (home appliances, office equipment, telecommunication equipment, measuring equipment, etc.). Their use in any application requiring radiation hardness assurance (e.g., aerospace equipment) is not supported.

When considering the use of Sanken products in applications where higher reliability is required (transportation equipment and its control systems or equipment, fire- or burglar-alarm systems, various safety devices, etc.), contact a company sales representative to discuss and obtain written confirmation of your specifications.

The use of Sanken products without the written consent of Sanken in applications where extremely high reliability is required (aerospace equipment, nuclear power-control stations, life-support systems, etc.) is strictly prohibited.

The information included herein is believed to be accurate and reliable. Application and operation examples described in this publication are given for reference only and Sanken assumes no responsibility for any infringement of industrial property rights, intellectual property rights, or any other rights of Sanken or any third party that may result from its use. The contents in this document must not be transcribed or copied without Sanken's written consent.