

品名順仕様一覧

製品名	絶対最大定格						I _{GSS}				I _{BSS}				V _{TH}			
	V _{DSS} (V)	V _{GSS} (V)	I _D (A)	I _{D (pulse)} (A)	P _D (W)	E _{AS} (mJ)	条件		条件		条件		条件					
							(nA)	V _{GS} (V)	(μA)	V _{DS} (V)	(V)	V _{DS} (V)	I _D (μA)					
	max		min	max	min	max	min	max	min	max	min	max						
2SK2420	60	±20	±30	±120	40	38	±100	±20		100	60	2.0	4.0	10	250			
2SK2701A	450	±30	±7	±28	35	130	±100	±30		100	450	2.0	4.0	10	1m			
2SK2803	450	±30	±3	±12	30	30	±100	±30		100	450	2.0	4.0	10	1m			
2SK2848	600	±30	±2	±8	30	10	±100	±30		100	600	2.0	4.0	10	250			
2SK2943	900	±30	±3	±12	30	60	±100	±30		100	900	2.0	4.0	10	1m			
2SK3003	200	±20	±18	±72	35	120	±100	±20		100	200	2.0	4.0	10	1m			
2SK3004	250	±20	±18	±72	35	120	±100	±20		100	250	2.0	4.0	10	1m			
2SK3199	500	±30	±5	±20	30	35	±100	±30		100	500	2.0	4.0	10	1m			
2SK3710	60	±20	±70	±140	90	468	±10μ	±15		100	60	2.0	4.0	10	1m			
2SK3711	60	±20	±70	±140	130		±10μ	±15		100	60	2.0	4.0	10	1m			
2SK3800	40	±20	±70	±140	80	400	±10	±15		100	40	2.0	4.0	10	1m			
2SK3801	40	±20	±70	±140	100	400	±10	±15		100	40	2.0	4.0	10	1m			
EKV550	50	±20	±50	±150	85	150	±10μ	±20		100	50	3.0	4.2	10	250			
FKP202	200	±30	±45	±180	40	200	±100	±30		100	200	3.0	4.5	10	1m			
FKP250A	250	±30	±50	±200	85	400	±100	±30		100	250	3.0	4.5	10	1m			
FKP252	250	±30	±25	±100	40	200	±100	±30		100	250	3.0	4.5	10	1m			
FKP253	250	±30	±20	±80	40	160	±100	±30		100	250	3.0	4.5	10	1m			
FKP280A	280	±30	±40	±160	85	400	±100	±30		100	280	3.0	4.5	10	1m			
FKP300A	300	±30	±30	±120	85	400	±100	±30		100	300	3.0	4.5	10	1m			
FKP330C	330	±30	±30	±120	85	500	±100	±30		100	330	3.0	4.5	10	1m			
FKV460S	40	+20, -10	±60	±180	60		+10, -5μ	+20, -10		100	40	1.0	2.5	10	250			
FKV550T	50	±20	±50	±150	35	150	±10μ	±20		100	50	1.0	2.5	10	250			
FKV550N	50	±20	±50	±150	35	150	±10μ	±20		100	50	3.0	4.2	10	250			
FKV575	50	±20	±75	±200	40	300	±100	±20		100	50	3.0	4.5	10	250			
FKV660S	60	+20, -10	±60	±180	60		+10, -5μ	+20, -10		100	60	1.0	2.5	10	250			
SKP202	200	±30	±45	±180	95	200	±100	±30		100	200	3.0	4.5	10	1m			
SKP253	250	±30	±20	±80	40	160	±100	±30		100	250	3.0	4.5	10	1m			

電気的特性																外形	質量 (g)
R _e (yfs)		条件		C _{iss}	C _{rss}	条件		R _{DS(ON)}									
(S)		V _{DS}	I _D	(pF)	(pF)	V _{GS}	V _{DS}	(Ω)		条件		(Ω)		条件			
min	typ	(V)	(A)	typ	typ	(V)	(V)	typ	max	(V)	(A)	typ	max	(V)	(A)		
13	20	10	15	2200		0	25	21m	28m	10	15					TO220F (FM20)	2.0
3.5	5	20	3.5	720	62	0	10	0.84	1.1	10	3.5					TO220F (FM20)	2.0
1.5	2.1	20	1.5	340	26	0	10	2.1	2.8	10	1.5					TO220F (FM20)	2.0
1.2	1.7	20	1	290	30	0	10	3	3.8	10	1					TO220F (FM20)	2.0
1.8	2.8	20	1.5	600	40	0	10	4	5	10	1.5					TO220F (FM20)	2.0
7	11	10	9	850	250	0	10	130m	175m	10	9					TO220F (FM20)	2.0
7	11	10	9	850	250	0	10	0.2	0.25	10	9					TO220F (FM20)	2.0
3.5	5.2	20	2.5	650	110	0	10	1.2	1.5	10	2.5					TO220F (FM20)	2.0
30	80	10	35	8000	1000	0	10	5m	6m	10	35					TO220S (面実装)	1.5
30	80	10	35	8000	1000	0	10	5m	6m	10	35					TO3P (MT100)	6.0
30	50	10	35	5100	860	0	10	5m	6m	10	35					TO220S (面実装)	1.4
30	50	10	35	5100	860	0	10	5m	6m	10	35					TO3P (MT100)	6.0
17		10	25	2000	500	0	10	12m	15m	10	25					TO220	2.0
18	28	10	22	2000	80	0	25	45m	53m	10	22					TO220F (FM20)	2.0
30	42	10	25	3800	210	0	25	37m	43m	10	25					TO3PF (FM100)	6.5
13	21	10	12	2000	70	0	25	68m	75m	10	12					TO220F (FM20)	2.0
8	17	10	10	1600	50	0	25	86m	95m	10	10					TO220F (FM20)	2.0
25	38	10	20	3800	190	0	25	46m	53m	10	20					TO3PF (FM100)	6.5
20	33	10	15	3800	180	0	25	57m	65m	10	15					TO3PF (FM100)	6.5
23	37	10	15	4600	220	0	25	50m	63m	10	15					TO3PF (FM100)	6.5
20		10	25	2800	600	0	10	7m	9m	10	25					TO220S (面実装)	1.5
20		10	25	2700	500	0	10	10m	13m	10	25					TO220F (FM20)	2.0
17		10	25	2000	500	0	10	12m	15m	10	25					TO220F (FM20)	2.0
30		10	37	3200	750	0	10	7m	10m	10	37					TO220F (FM20)	2.0
20		10	25	2500	150	0	10	11m	14m	10	25					TO220S (面実装)	1.5
18	28	10	22	2000	80	0	25	45m	53m	10	22					TO263 (面実装)	1.5
8	17	10	10	1600	50	0	25	86m	95m	10	10					TO263 (面実装)	1.5



外形図一覧

■外形図一覧

・ TO-220F

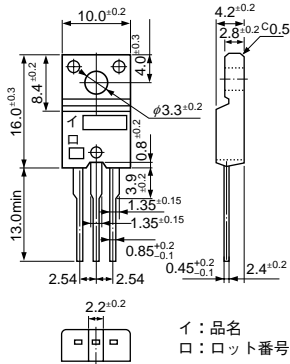

・ TO-220

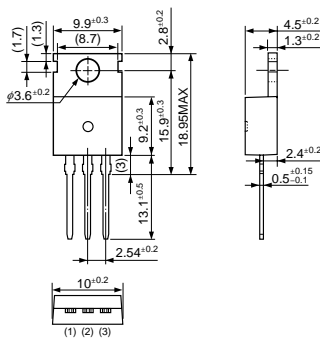

・ TO-3P

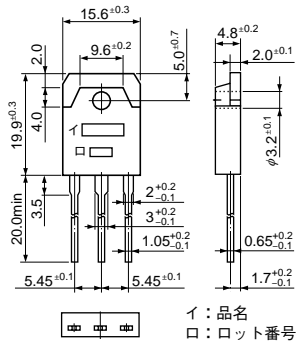

・ TO-3PF

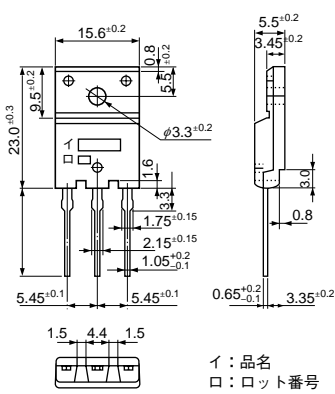

・ MT-200

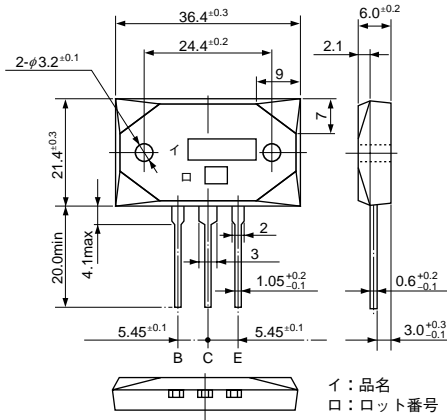

・ TO-220S

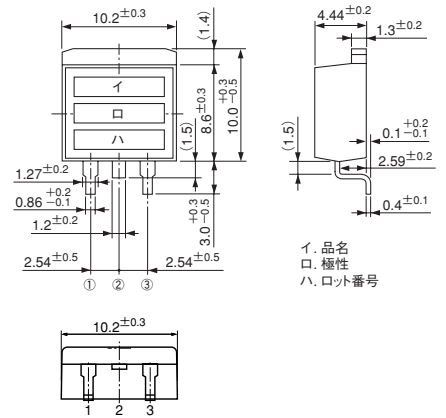

・ TO-263

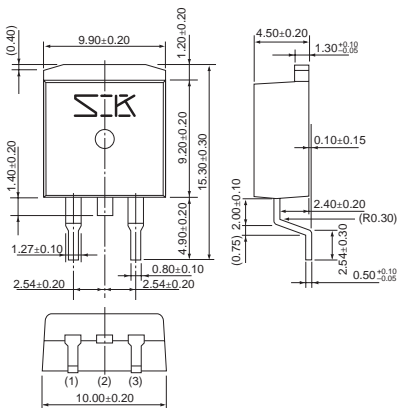

・ TO3P-5pin
NPN

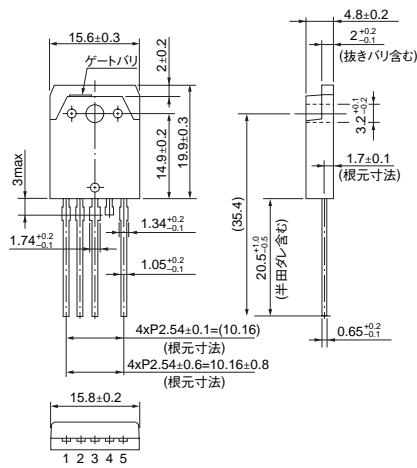

PNP

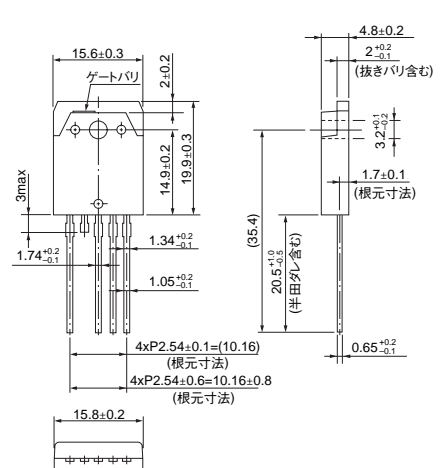

(単位: mm)