

Application Note

Surface Molding Chopper type Switching Regulator IC

SPI-8010A

Not Recommended for New Designs

6th Edition October 2013

SANKEN ELECTRIC CO., LTD

— — — Contents — — —

1. General Description		
1-1 Features	-----	3
1-2 Applications	-----	3
1-3 Type	-----	3
2. Specification		
2-1 Package Information	-----	4
2-2 Ratings	-----	5
2-3 Circuit Diagram	-----	7
3. Operational Description		
3-1 PWM Output Voltage Control	-----	9
3-2 Overcurrent Protection / Thermal Shutdown	-----	10
4. Cautions		
4-1 External Components	-----	11
4-2 Pattern Design Notes	-----	15
4-3 Operation Waveform Check	-----	16
4-4 Thermal Design	-----	17
5. Applications		
5-1 Soft Start	-----	19
5-2 Output ON / OFF Control	-----	19
5-3 Controllable Output Voltage	-----	19
5-4 Reverse Bias Protection	-----	20
6. Typical Characteristics	-----	21
7. Terminology	-----	22

1. General Description

The SPI-8010A is a chopper type switching regulator IC which is provided with various functions required for the buck switching regulator and protection functions. A high speed, high accuracy and high efficiency switching regulator of 250 KHz operating frequency can be composed. Since a package having a heat sink on the backside of IC is used, thermal resistance can be significantly decreased

● 1-1 Features

- Compact size and large output current of 3A
The maximum output current of 3A for the outline of HSOP 16
- High efficiency of 86% ($V_{IN} = 20V / V_o / I_o = 5V / 1A$)
As the DMOS is used in the output stage, heat generation can be reduced and heat dissipation pattern can be made smaller.
- Reference oscillation by a built-in timing capacitor
No external capacitor for setting the oscillation frequency is required.
- Built-in functions for overcurrent and thermal shutdown
The foldback type overcurrent protection and thermal shutdown circuit are built in.
(Automatic recovery type)
- Soft start function (capable of ON/OFF output)
By adding an external capacitor, it is possible to delay the rise speed of the output voltage. ON/OFF control of the output is also possible.
- The output voltage can be adjusted by an external resistor.
By using 2 pieces of external resistors, the output voltage is variable in the range of +1V to + 14V.

● 1-2 Applications

For on-board local power supplies, power supplies for OA equipment, stabilization of secondary output voltage of regulator and power supply for telecommunication equipment

● 1-3 Type

- Type: Semiconductor integrated circuits (monolithic IC)
- Structure: Resin molding type (transfer molding)

2. Specification

● 2-1 Package Information

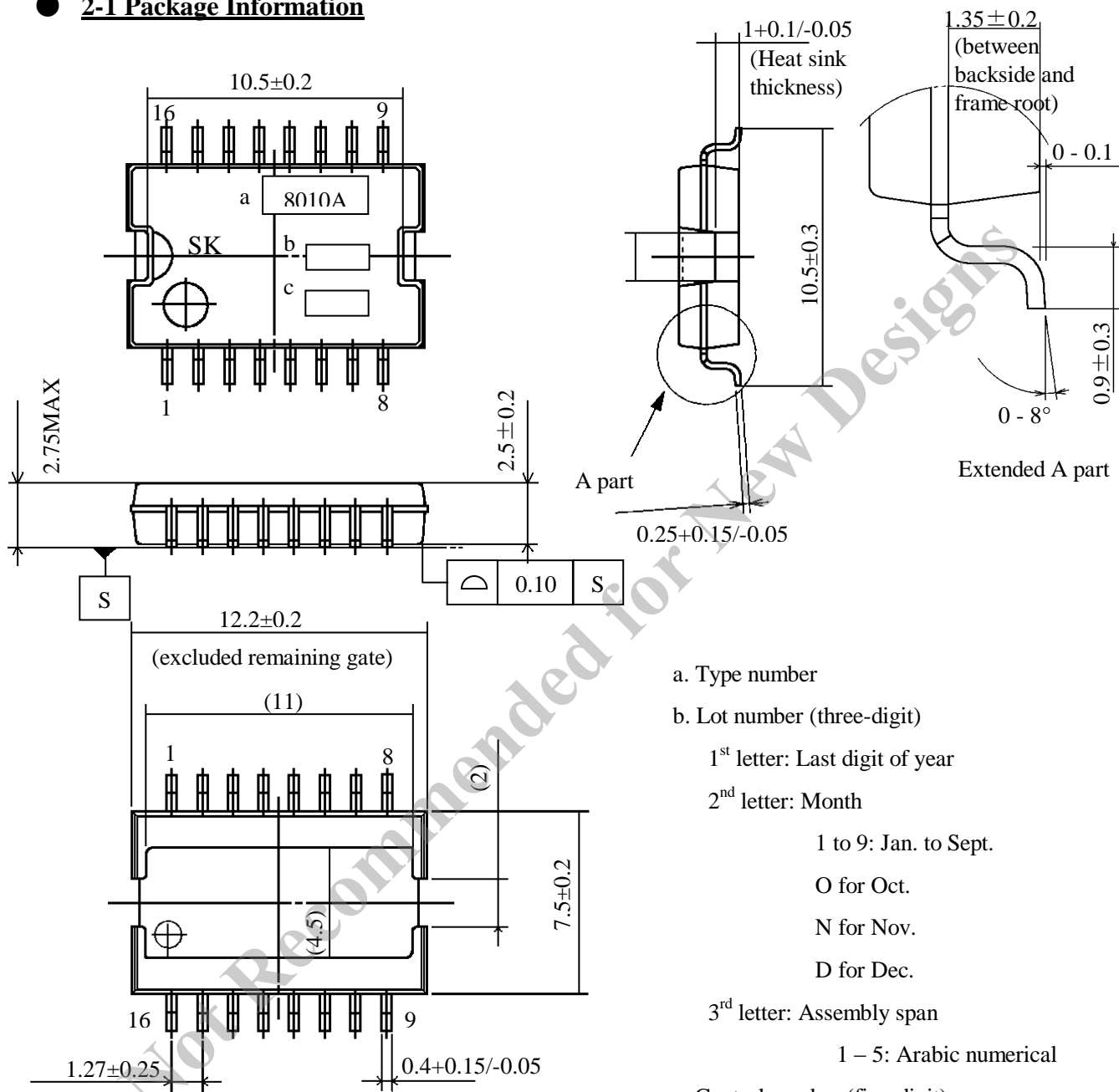

- a. Type number
- b. Lot number (three-digit)
- 1st letter: Last digit of year
 - 2nd letter: Month
 - 1 to 9: Jan. to Sept.
 - O for Oct.
 - N for Nov.
 - D for Dec.
 - 3rd letter: Assembly span
 - 1 – 5: Arabic numerical
- c. Control number (five-digit)

Pin Assignment

1.AGND	9.N.C
2.N.C	10.N.C
3.DGND	11.VIN
4.CE/SS	12.BS
5.Reg	13.N.C
6.N.C	14.Comp
7.SWout	15.VREF
8.N.C	16.N.C

● 2-2 Ratings

Absolute Maximum Rating

Parameter	Symbol	Rating	Unit	Condition
Input Voltage	V_{IN}	53	V	
Allowable Power Dissipation	P_d	2.4	W	Glass epoxy board: 7000mm ² (Copper foil area in package: 3080mm ²)
Junction Temperature	T_j	125	°C	
Storage Temperature	T_{stg}	-40 - 125	°C	
Thermal Resistance (Between Junction and case)	θ_{j-c}	18	°C /W	Glass epoxy board: 7000mm ² (Copper foil area in package: 3080mm ²)
Thermal Resistance (Between Junction and ambient)	θ_{j-a}	41.7	°C /W	Glass epoxy board: 7000mm ² (Copper foil area in package: 3080mm ²)

Recommended operation conditions

Parameter	Symbol	Ratings		Unit	Conditions
		MIN	MAX		
Input Voltage	V_{CC}	8 or V_o+3	50	V	
Output Voltage	V_o	1	14	V	
Output Current *1	I_{OUT}	0.02	3	A	
Junction Temperature in Operation	T_{jop}	-30	125	°C	
Operation Temperature	T_{op}	-30	125	°C	

*1: It is strongly recommended to apply over 20mA on output current. It may cause unstable output voltage if output current is less than 20mA.

Electrical Characteristics

(Ta=25°C)

Parameter	Symbol	Ratings			Unit	Measurement Conditions
		MIN	TYP	MAX		
Setting Reference Voltage	VREF	0.97	1.00	1.03	V	VIN=12V, IO=1A
Output Voltage Temperature Coefficient	$\Delta V_{REF}/\Delta T$		±0.5		mV/°C	
Efficiency	Eff		86		%	VIN=20V, IO=1A, VO=5V
Operation Frequency	fosc		250		kHz	VIN=12V, IO=1A
Line Regulation	VLine		20	40	mV	VIN=10 - 30V, IO=1A
Load Regulation	VLoad		10	30	mV	VIN=12V, IO=0.1 - 1.5A
Overcurrent Protection Start Current	IS	3.1			A	VIN=12V
Circuit Current in Non-operation 1	Iq		7		mA	VIN=12V, IO=0A
Circuit Current in Non-operation 2	Iq(off)			400	μA	VIN=12V VON/OFF=0.3V
CE/SS terminal	Low Level Voltage	VSSL		0.5	V	
	Flow-out Current at Low Level Voltage	ISSL		50	μA	VSSL=0V

● **2-3 Circuit Diagram**

2-3-1 Internal Equivalent Circuit

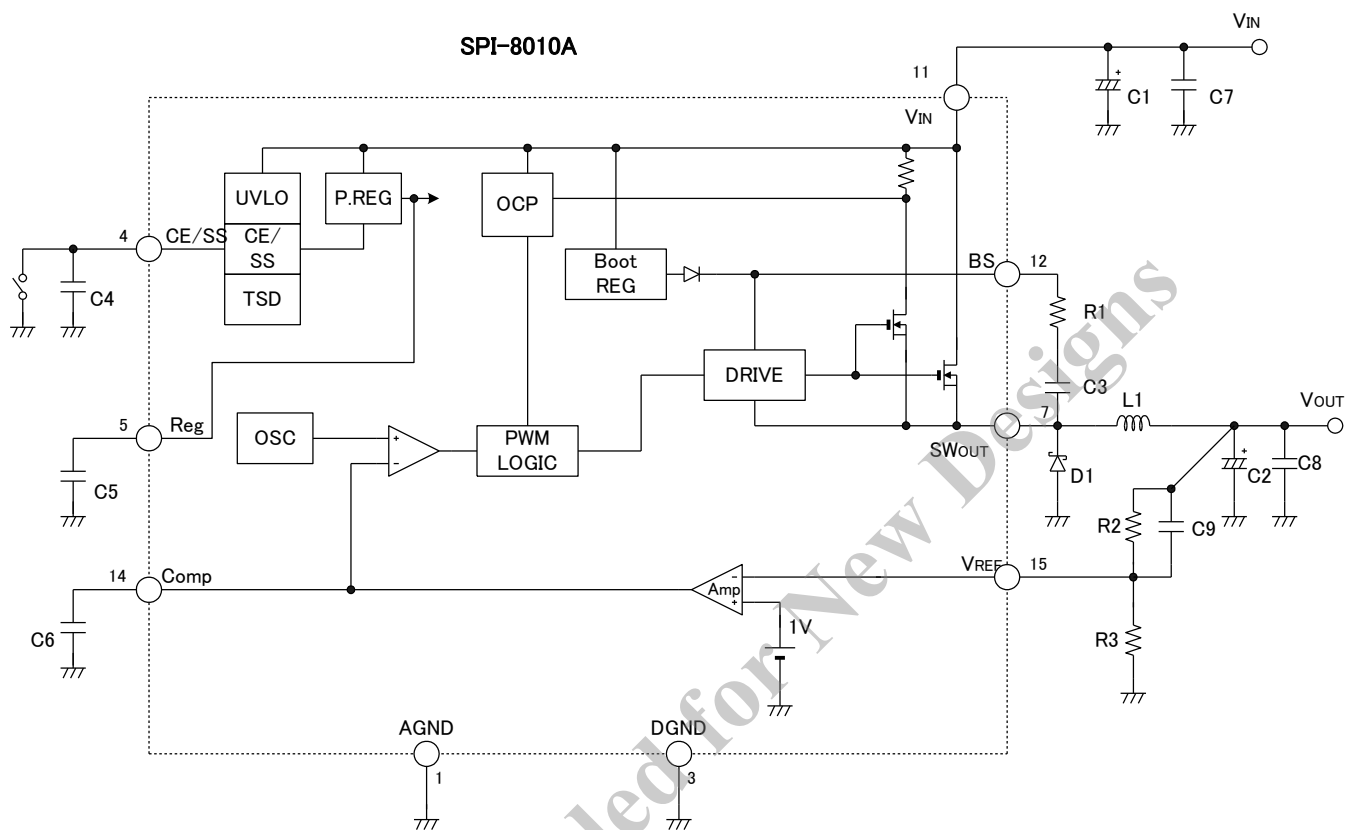

2-3-2 Typical Connection Diagram

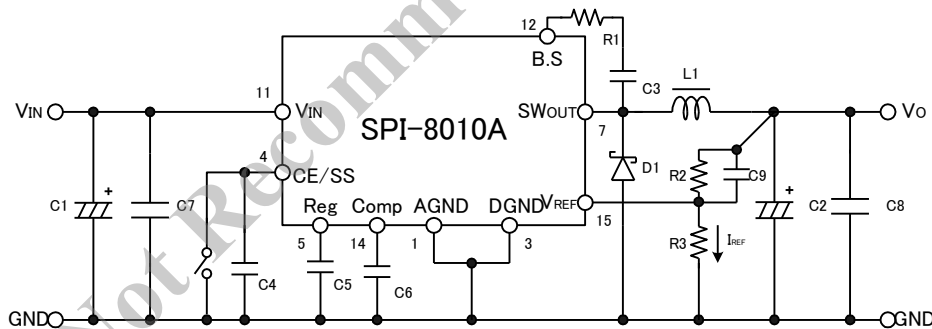

C1: 220 μ F/63V

C2: 470 μ F/25V

C3: 0.1 μ F

C4: 1000pF

C5: 0.1 μ F

C6: 0.047 μ F

C7: 0.1 μ F

C8: 0.1 μ F

C9: 6800pF

R1: 47 Ω

L1: 47 μ H

D1: SPB-G56S

(SANKEN)

2-3-3 Main Components List

Component	Spec	Recommended materials
C1	220 μ F / 63V / Electrolytic capacitor	EMVY630GTR221MLHoS (Nippon Chemi-Con)
C2	470 μ F / 25V / Electrolytic capacitor	UUD1E471MNR1GS (nichicon)
C3, C5	0.1 μ F / 10V / Ceramic capacitor	GRM31BR11A105MA01B (MURATA)
C4	0.1 μ F / 50V / Ceramic capacitor	GRM21BR11H104MA01B (MURATA)
C6	0.1 μ F / 50V / Ceramic capacitor	GRM21BR11H104MA01B (MURATA)
C7, C8	0.1 μ F / 50V / Ceramic capacitor	GRM21BR11H104MA01B (MURATA)
C9	0.1 μ F / 50V / Ceramic capacitor	GRM21BR11H104MA01B (MURATA)
L1	47 μ H / Inductor	SLF12575T-470M2R7 (TDK)
D1, D2	1.5A / 60V / Schottky barrier diode	SPB-G56S (Sanken)
R1	47 Ω	-
R2	2k Ω ($V_O = 5V$)	-
R3	500 Ω	-

Not Recommended for New Designs

3. Operational Description

● **3-1 PWM Output Voltage Control**

In the SPI-8010A series, the output voltage is controlled by the PWM system and the IC integrates the PWM comparator, oscillator, error amplifier, reference voltage, output transistor drive circuit etc. The triangular wave output ($\approx 250\text{KHz}$) from the oscillator and the output of the error amplifier are given to the input of the PWM comparator. The PWM comparator compares the oscillator output with the error amplifier output to turn on the switching transistor for a time period when the output of the error amplifier exceeds the oscillator output.

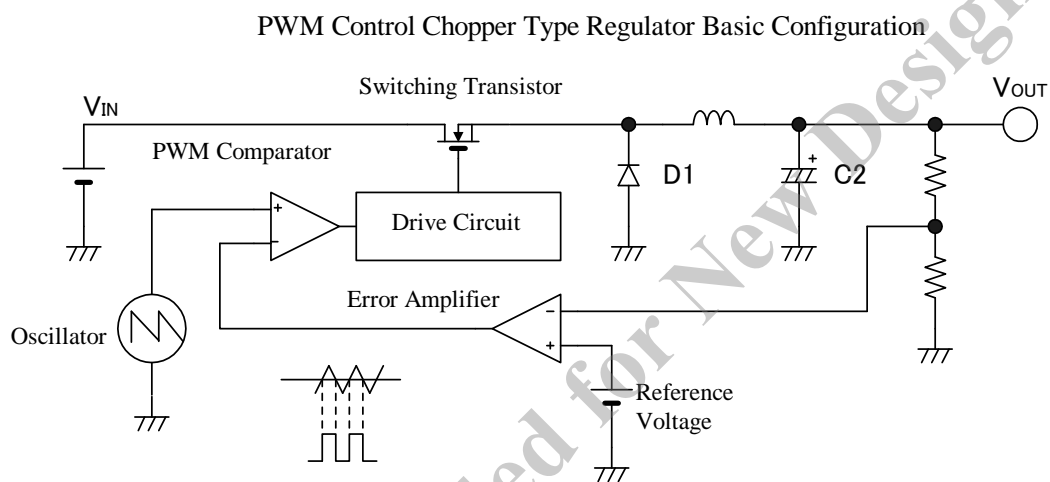

The error amplifier output and the oscillator output are compared by the PWM comparator to generate the drive signal of rectangular wave and to drive the switching transistor.

On the assumption that the output voltage attempts to rise, the output of the error amplifier is decreased, because the error amplifier is of inverting type. When the output of the error amplifier is decreased, the time period where it exceeds the triangular wave of the oscillator is decreased to shorten the ON time of the switching transistor and as a result, the output voltage is maintained constant.

As described above, the output voltage is controlled by varying the ON time of the switching transistor with the switching frequency fixed (the higher is V_{IN} , the shorter is the ON time of the switching transistor.)

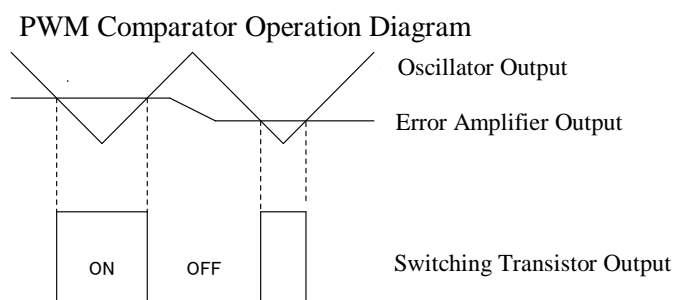

The rectangular wave output of the switching transistor is smoothed by the LC low pass filter composed of a choke coil and a capacitor to supply stabilized DC voltage to the load.

● 3-2 Overcurrent Protection / Thermal Shutdown

The SPI-8010A includes the foldback type overcurrent protection circuit. The overcurrent protection circuit detects the peak current of a switching transistor and when the peak current exceeds the set value, the ON time of the transistor is compulsorily shortened to limit the current by lowering the output voltage. When the overcurrent condition is released, the output voltage will be automatically restored.

Output Voltage Characteristic on Overcurrent

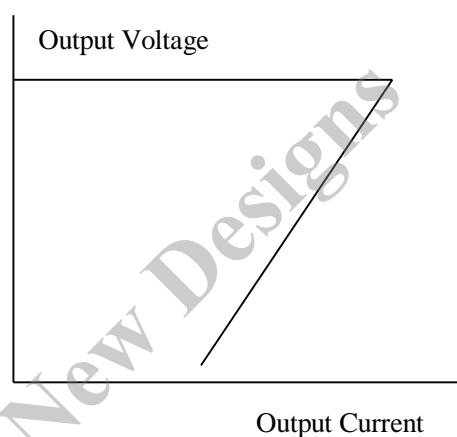

The thermal shutdown circuit detects the semiconductor junction temperature of the IC and when the junction temperature exceeds the set value, the output transistor is stopped and the output is turned OFF. When the junction temperature drops from the set value for overheat protection by around 15°C, the output transistor is automatically restored.

* Note for thermal shutdown characteristic

This circuit protects the IC against overheat resulting from the instantaneous short circuit, but it should be noted that this function does not assure the operation including reliability in the state that overheat continues due to long time short circuit.

Output Voltage Characteristic on Thermal Shutdown

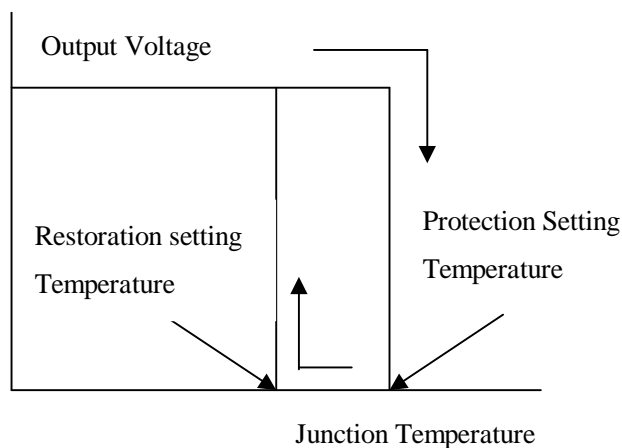

4. Cautions

● 4-1 External Components

4-1-1 Choke coil L

The choke coil L1 is one of the most important components in the chopper type switching regulator. In order to maintain the stable operation of the regulator, such dangerous state of operation as saturation state and operation at high temperature due to heat generation must be avoided.

The following points should be taken into consideration for the selection of the choke coil.

a) The choke coil should be fit for the switching regulator.

The coil for a noise filter should not be used because of large loss and generated heat.

b) The inductance value should be appropriate.

The larger is the inductance of the choke coil, the less is the ripple current flowing across the choke coil, and the output ripple voltage drops and as a result, the overall size of the coil becomes larger.

On the other hand, if the inductance is small, the peak current flowing across the switching transistor and diode is increased to make the ripple voltage higher and this operation state is not favorable for maintaining the stable operation.

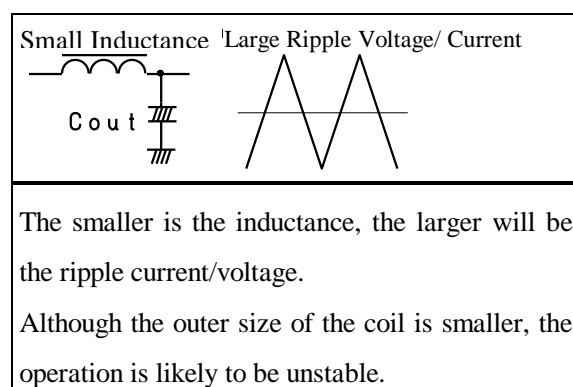
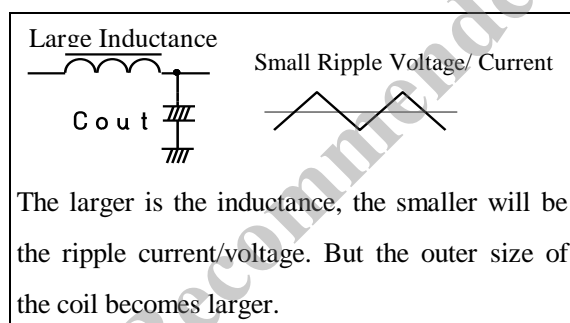

The inductance value shown in the specifications should be considered as a reference value for the stable operation and the appropriate inductance value can be obtained by the following equation.

ΔI_L shows the ripple current value of the choke coil and the lower limit of inductance is set as described in the following.

- In the case that the output current to be used is nearly equal to the maximum rating (3A) of the SPI-8010A:
output current \times 0.2- 0.3
- In the case that the output current to be used is approximately 1A or less: output current \times 0.5 - 0.6

$$L = \frac{(V_{in} - V_{out}) \cdot V_{out}}{\Delta I_L \cdot V_{in} \cdot f} \quad \text{--- (1)}$$

For example, where $V_{IN} = 25V$, $V_{Out} = 5V$, $\Delta I_L = 0.35A$, frequency = 250kHz,

$$L1 = \frac{(25-5) \times 5}{0.35 \times 25 \times 250 \times 10^3} \approx 45.7 \mu H$$

As shown above, the coil of about 47 μ H may be selected.

c) The rated current shall be met.

The rated current of the choke coil must be higher than the maximum load current to be used. When the load current exceeds the rated current of the coil, the inductance is sharply decreased to the extent that it causes saturation state at last. Please note that overcurrent may flow since the high frequency impedance becomes low.

d) Noise shall be low.

In the open magnetic circuit core which is of drum shape, since magnetic flux passes outside the coil, the peripheral circuit may be damaged by noise. It is recommended to use the toroidal type, EI type or EE type coil which has a closed magnetic circuit type core as much as possible.

4-1-2 Input Capacitor C1

The input capacitor is operated as a bypass capacitor of the input circuit to supply steep current to the regulator during switching and to compensate the voltage drop of the input side. Therefore, the input capacitor should be connected as close as to the regulator IC.

In addition, in the case that the smoothing capacitor of the AC rectifier circuit is located in the input circuit, the input capacitor may be also used as a smoothing capacitor, but similar attention should be paid.

The selection of C1 shall be made in consideration of the following points:

- a) The requirement of withstand voltage shall be met.
- b) The requirement of the allowable ripple voltage shall be met.

Current Flow of C1

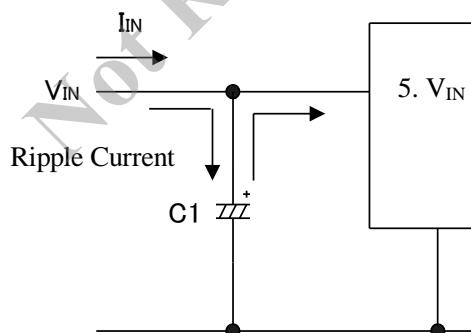

Current Waveform of C1

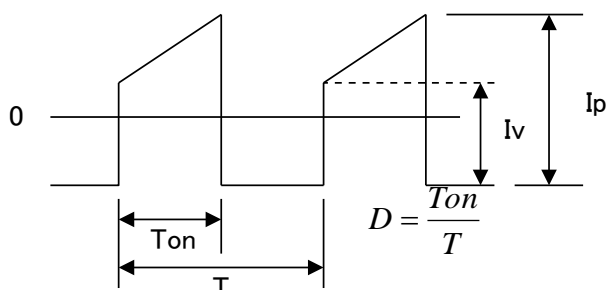

The ripple current of the input capacitor is increased in accordance with the increase of the load current.

If the withstanding voltages or allowable ripple voltages are exceeded or used without derating, it is in danger of causing not only the decreasing the capacitor lifetime (burst, capacitance decrease, equivalent impedance increase, etc) but also the abnormal oscillations of regulator.

Therefore, the selection with sufficient margin is needed.

The effective value of ripple current flowing across the input capacitor can be calculated by the following equation:

$$I_{rms} \approx 1.2 \times \frac{V_o}{V_{in}} \times I_{out} \quad \text{--- (2)}$$

For instance, where $I_o=3A$, $V_{IN}=20V$, $V_o=5V$,

$$I_{rms} \approx 1.2 \times \frac{5}{20} \times 3 = 0.9A$$

Therefore, it is necessary to select the capacitor with the allowable ripple current of 0.9A or higher.

4-1-3 Output Capacitor C2

The output capacitor C2 composes a LC low pass filter together with a choke coil L1 and functions as a rectifying capacitor of switching output. The current equivalent to the pulse current ΔI_L of the choke coil current is charged and discharged in the output capacitor. Therefore, it is necessary to meet the requirements of withstand voltage and allowable ripple current with sufficient margin like the input capacitor.

The following points should be taken into consideration.

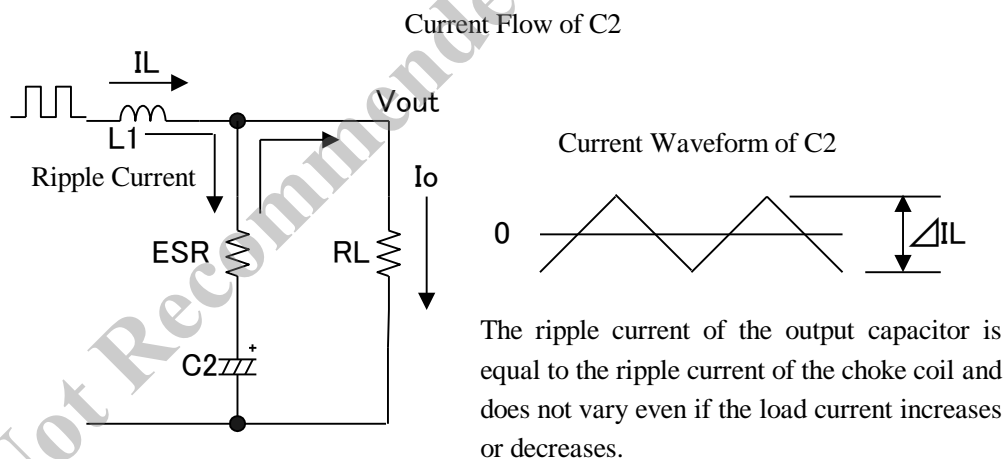

a) Allowable Ripple Current

The ripple current effective value of the output capacitor is calculated by the equation.

$$I_{rms} = \frac{\Delta I_L}{2\sqrt{3}} \quad \text{--- (3)}$$

When $\Delta I_L = 0.5A$,

$$I_{rms} = \frac{0.5}{2\sqrt{3}} \doteq 0.14A$$

Therefore a capacitor having the allowable ripple current of 0.14A or higher is required.

The output ripple voltage is determined by a product of the pulse current ΔI_L (=C2 discharge and charge current) of

the choke coil current and the ESR

$$V_{rip} = \Delta I_L \cdot C_2 ESR \quad \text{--- (4)}$$

b) DC equivalent series resistance (ESR)

When the ESR is too large, it causes abnormal oscillation due to increase of ripple voltage. On the other hand, when the ESR is too small, it causes insufficient phase margin.

The output ripple voltage is determined by a product of the pulse current ΔI_L (=C2 discharge and charge current) of the choke coil current and the ESR, and the output ripple voltage which is 0.5 - 1% of the output voltage (for example, 25mV where 0.5% at $V_{OUT} = 5V$.) is good for the stable operation. Please refer to the equations (4) and (5) to obtain the output ripple voltage. It should be noted that the ESR is changeable subject to temperature and it is especially decreased at high temperature.

$$V_{rip} \approx \frac{(V_{in} - V_{out})V_{out}}{L \cdot V_{in} \cdot f} ESR \quad \text{--- (5)}$$

$$V_{rip} \approx \Delta I_L \cdot ESR \quad \text{--- (6)}$$

However, if the ESR of the output capacitor is too low (10 - 20m Ω or lower), the phase margin within the feedback loop of the regulator will be short to make the operation unstable. Therefore, it is not appropriate that a tantalum capacitor or a laminated ceramic capacitor is used for the output capacitor as an independent component. However, connecting a tantalum capacitor or a laminated ceramic capacitor in parallel with an electrolytic capacitor is effective in reducing the output ripple voltage only when it is used at low temperature (< 0°C).

In addition, in order to further decrease the ripple voltage, as shown below, it is also effective to add one stage of the LC filter to form the π type filter.

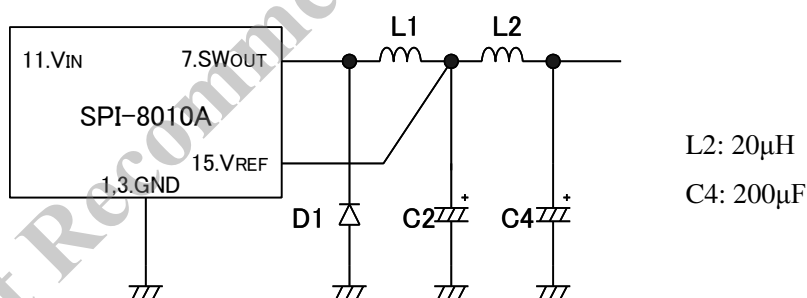

The abnormal oscillation can be caused unless the output voltage detection point (wiring to the V_{os} terminal) is placed before the second stage filter if the second stage filter is added. Therefore, the care should be taken.

It should be noted that the operating stability is more influenced by the ESR than the capacitance as described above if the requirements of withstand voltage and allowable ripple current are met.

4-1-4 Flywheel Diode D1

The flywheel diode D1 is to discharge the energy which is stored in the choke coil at switching OFF.

For the flywheel diode, the Schottky barrier diode must be used. If a general rectifying diode or fast recovery diode is used, the IC may be destroyed by applying reverse voltage due to the recovery and ON voltage.

In addition, since the output voltage from the SW_{OUT} terminal (pin 7) of the SPI-8010A series is almost equivalent to the input voltage, the flywheel diode with the reverse withstand voltage of the input voltage $\times 1.2$ or higher should be used.

● 4-2 Pattern Design Notes

4-2-1 High Current Line

Since high current flows in the bold lines in the connection diagram, the pattern should be as wide and short as possible.

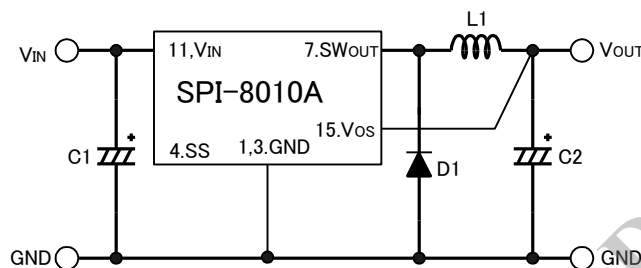

4-2-2 Input / Output Capacitor

The input capacitor C1 and the output capacitor C2 should be connected to the IC as close as possible. If the rectifying capacitor for AC rectifier circuit is on the input side, it can be used as an input capacitor. However, if it is not close to the IC, the input capacitor should be connected in addition to the rectifying capacitor.

Since high current is discharged and charged through the leads of input/output capacitor at high speed, the leads should be as short as possible.

A similar care should be taken for the patterning of the capacitor.

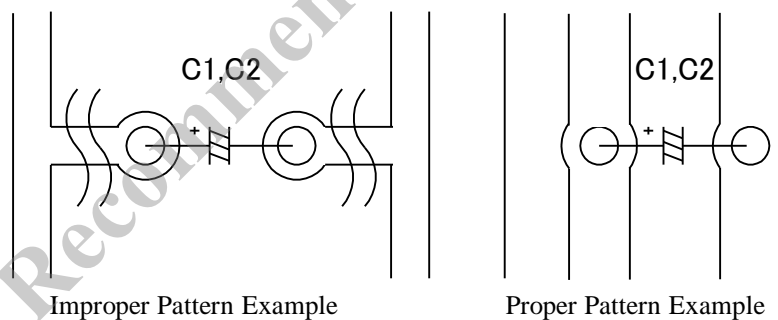

4-2-3 Sensing Terminal

The output voltage sensing terminal Vos shall be connected near the output capacitor C2 as much as possible. If it is connected far from C2, it should be noted that abnormal oscillation may happen due to the low regulation and increased switching ripple.

● 4-3 Operation Waveform Check

It can be checked by the waveform between the pin 7-1 and 3 (SW_{OUT} - GND waveform) of the SPI-8010A whether the switching operation is normal or not.

The examples of waveforms at normal and abnormal operations are shown below:

1. Normal Operation (continuous area)

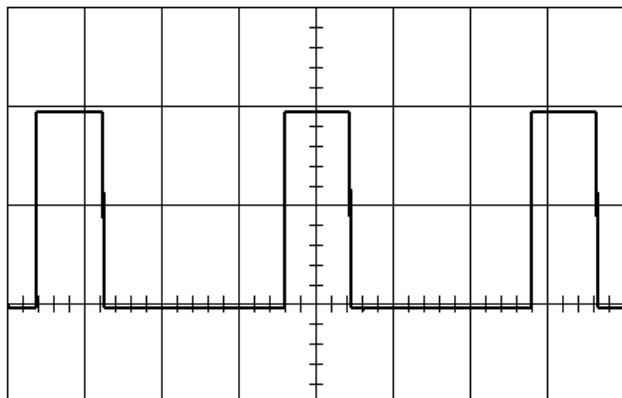

2. Normal Operation (discontinuous area)

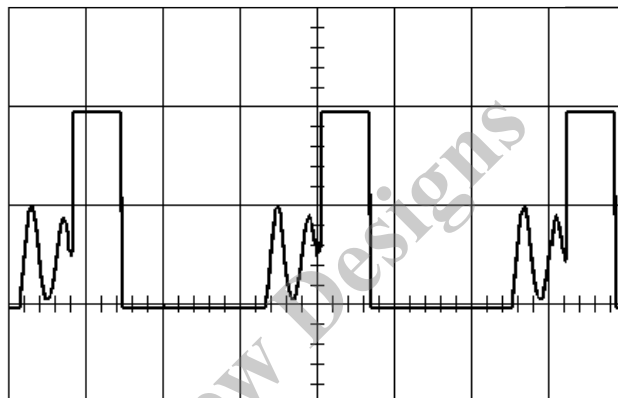

3. When C1 is far from IC

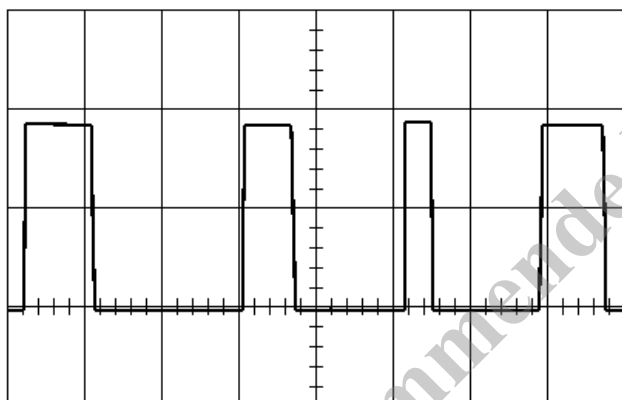

4. When C2 is far from IC

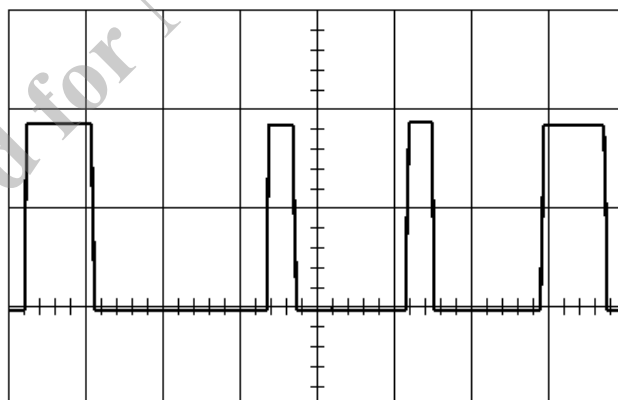

The continuous area is an area where the DC component of the triangular wave is superimposed on the current flowing across the choke coil and the discontinuous area is an area where the current flowing across the choke coil is intermittent (a period of zero current may happen.) because the current flowing across the choke coil is low.

Therefore, when the load current is high, the area is a continuous area and when the same current is low, the area is a discontinuous area.

In the continuous area, the switching waveform is formed in the normal rectangular waveform (waveform 1) and in the discontinuous area, damped oscillation is caused in the switching waveform (waveform 2), but this is a normal operation without any problem.

In the meantime, when the IC is far from C1 and C2, jitter which disturbs the ON - OFF time of switching will happen as shown in the waveforms (3, 4). As described above, C1 and C2 should be connected close to the IC.

● **4-4 Thermal Design**

4-4-1 Calculation of Heat Dissipation

The relation among the power dissipation Pd of regulator, junction temperature Tj, case temperature Tc, board temperature Tfin and ambient temperature Ta is as follows:

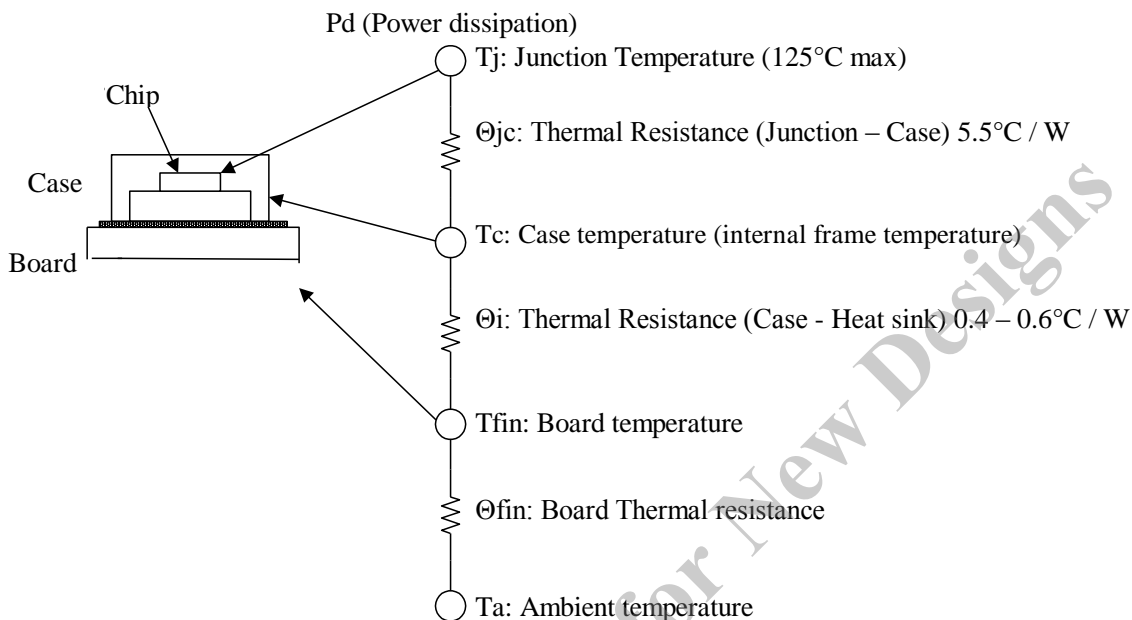

$$Pd = \frac{Tj - Tc}{\theta_{jc}} \quad \text{--- (7)}$$

$$Pd = \frac{Tj - Tfin}{\theta_{jc} + \theta_i} \quad \text{--- (8)}$$

$$Pd = \frac{Tj - Ta}{\theta_{jc} + \theta_i + \theta_{fin}} \quad \text{--- (9)}$$

The TjMAX is an inherent value for each product, therefore it must be strictly observed.

For this purpose, it is required to design the board pattern in compliance with PdMAX, TaMAX (determination of theta_fin).

The heat derating graphically describes this relation.

The designing of the heat sink is carried out by the following procedure:

- 1) The maximum ambient temperature Ta MAX in the set is obtained.
- 2) The maximum power dissipation PdMAX is obtained by varying input/ output conditions.

$$Pd = Vo \cdot Io \left(\frac{100}{\eta_x} - 1 \right) - Vf \cdot Io \left(1 - \frac{Vo}{Vin} \right) \quad \text{--- (10)}$$

* eta_x= efficiency (%), Vf= diode forward voltage

- 3) The size of heat sink is determined from the intersection of the heat derating.

The required thermal resistance of the heat sink can be also calculated. The thermal resistance required for the heat sink is calculated by the following equation:

$$\theta_i + \theta_{fin} = \frac{T_j - T_a}{P_d} - \theta_{jc} \quad \text{--- (11)}$$

An example of heat calculation for using SPI-8010A under the conditions of $V_{IN} = 10V$, $V_{OUT} = 5V$, $I_{OUT} = 3A$ and $T_a = 85^\circ C$ is shown below. Where efficiency $\eta = 87\%$, $V_f = 0.5V$ from the typical characteristics,

$$P_d = 5 \times 3 \times \left(\frac{100}{87} - 1 \right) - 0.5 \times 3 \times \left(1 - \frac{5}{10} \right) \doteq 1.49W$$

$$\theta_i + \theta_{fin} = \frac{125 - 85}{1.49} - 18 \doteq 8.85^\circ C/W$$

As a result, the heat sink with the thermal resistance of $9^\circ C/W$ or less is required. As described above, the thermal resistance of board is determined, but the derating of 10 - 20% or more is used. Actually, heat dissipation effect significantly changes depending on the difference in component mounting. Therefore, board temperature or case temperature at mounted should be checked.

4-4-2 Installation to Board

Connection of GND pattern to the back side heat sink

The SPI-8010A adopts a package having a heat sink on the backside of IC. In order to enhance the heat dissipation effect, it is recommended to connect the GND pattern to the back side heat sink.

Not Recommended for New Designs

5. Applications

● 5-1 Soft Start

When a capacitor is connected to No.4 terminal of the SPI-8010A, soft start operation can be made for the purpose of providing delay time from the application of input voltage to the rise of output voltage. By means of this operation, the state of high input voltage is realized prior to the operation of a regulator.

In the case of the buck converter type switching regulator, as the input voltage becomes higher the input current is reduced, therefore the operation can be started with less current. In the case of the actual equipment, more or less variation takes place because of the influence from the rise time of input power supply.

The C4 should be used with 4700 pF or less.

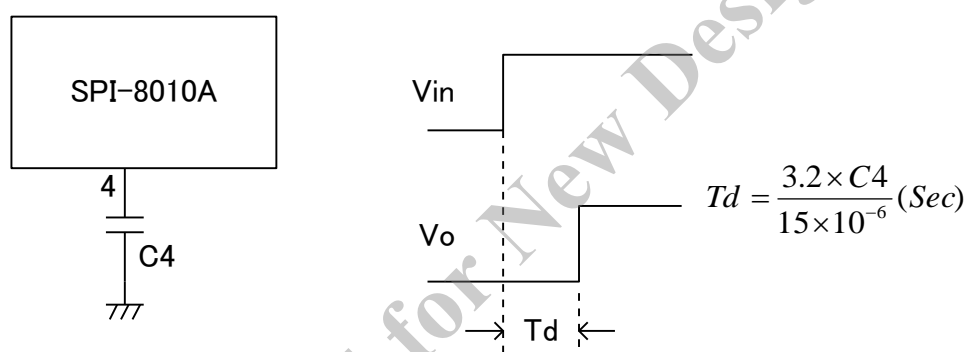

● 5-2 Output ON / OFF Control

The output ON-OFF control is possible using No.4 terminal, CE/ SS terminal. The output is turned OFF when the terminal 4 voltage falls to low by switch such as open collector. It is possible to use the soft start together.

Since CE/ SS terminal has been already pulled up in the IC inside, no voltage shall be applied from the external side.

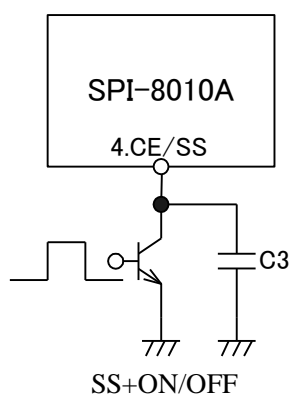

● 5-3 Controllable Output Voltage

R2 and R3 are resistors for setting the output voltage. It should be set in a manner that I_{REF} is around 2mA.

The equation by which the values of R2 and R3 can be calculated is as follows:

$$R2 = \frac{(V_{OUT} - V_{REF})}{I_{REF}} = \frac{(V_{OUT} - 1)}{2 \times 10^{-3}} (\Omega), \quad R3 = \frac{V_{REF}}{I_{REF}} = \frac{1}{2 \times 10^{-3}} \doteq 500 (\Omega)$$

● 5-4 Reverse Bias Protection

A diode for reverse bias protection is required between input and output when the output voltage is higher than the input terminal voltage, such as in battery chargers.

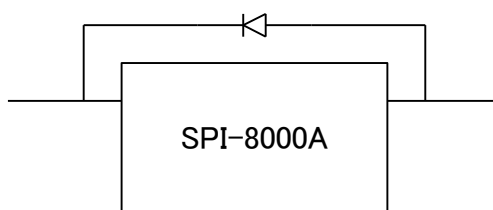

Not Recommended for New Designs

6. Typical Characteristics

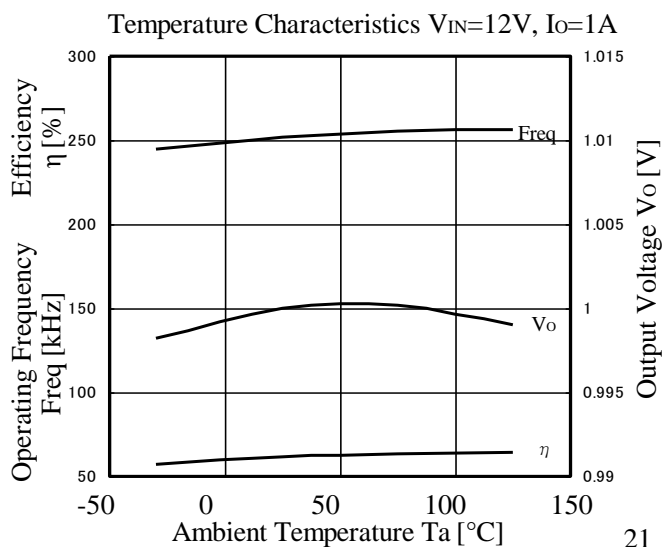
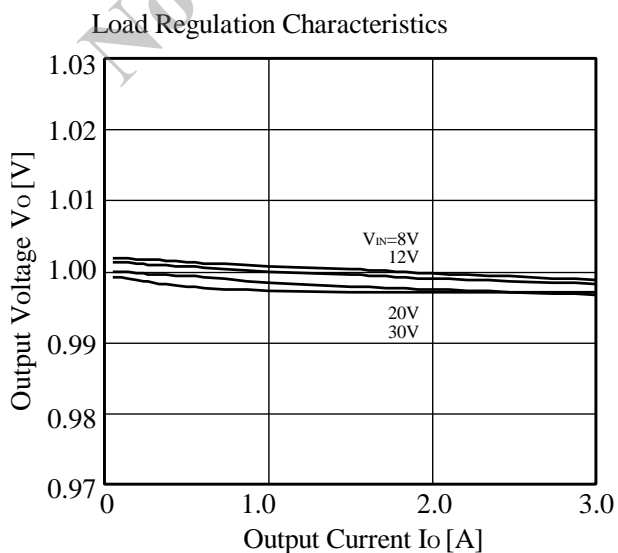
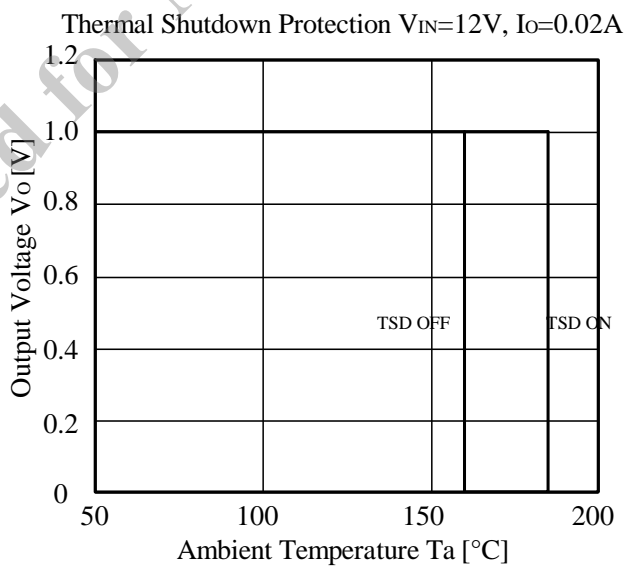
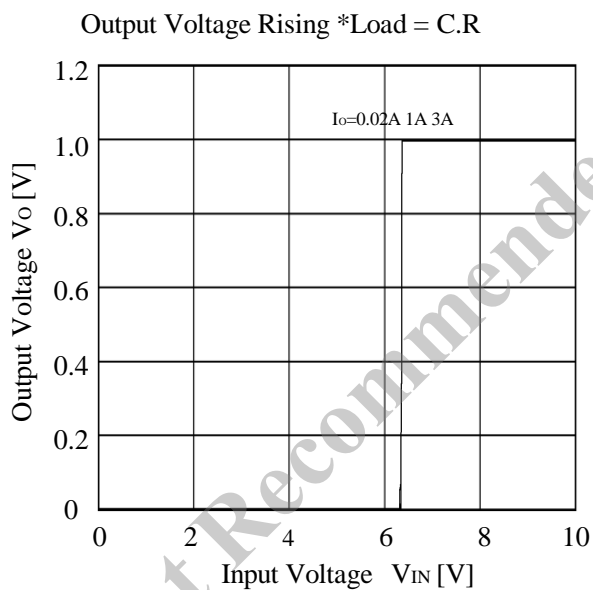
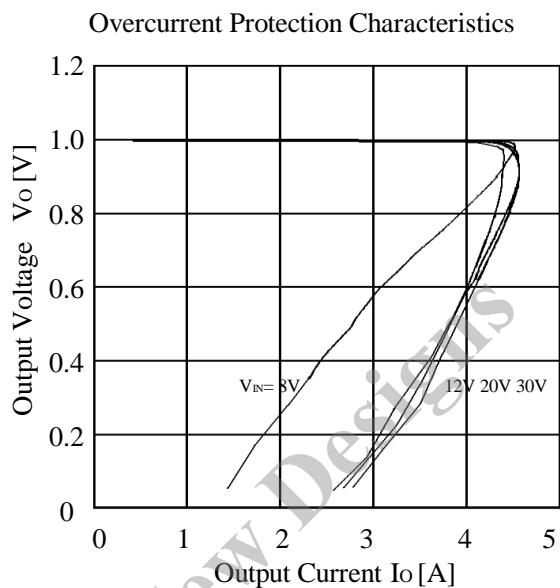
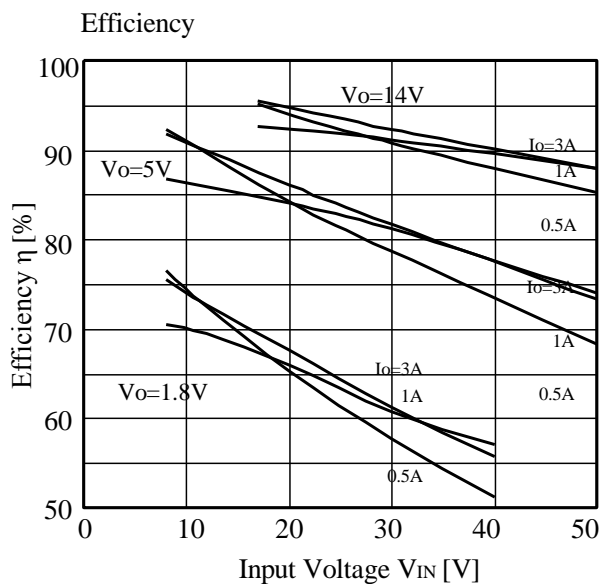

7. Terminology

- Jitter

It is a kind of abnormal switching operations and is a phenomenon that the switching pulse width varies in spite of the constant condition of input and output. The output ripple voltage peak width is increased when a jitter occurs.

- Recommended Operation Conditions

It shows the operation conditions required for maintaining normal circuit functions. It is required to meet the conditions in actual operations.

- Absolute Maximum Ratings

It shows the destruction limits. It is required to take care so that even one item does not exceed the standard value for a moment during instantaneous or normal operation.

- Electrical Characteristics

It is the specified characteristic value in the operation under the conditions shown in each item. If the operating conditions are different, it may be out of the specifications.

- PWM (Pulse Width Modulation)

It is a kind of pulse modulation systems. The modulation is achieved by changing the pulse width in accordance with the variation of modulation signal waveform (the output voltage for chopper type switching regulator).

- ESR (Equivalent Series Resistance)

It is the equivalent series resistance value of a capacitor. It operates in a similar way to the resistor series-connected to the capacitor.

Not Recommended for New Designs

Caution/ Warning

- The contents of this document are subject to change without prior notice for improvement etc. Please make sure that this is the latest information prior to the use of the products.
- Application and operation examples described in this document are quoted for the sole purpose of reference for the use of the products herein and Sanken can assume no responsibility for any infringement of industrial property rights, intellectual property rights or any other rights of Sanken or any third party which may result from its use.
- When using the products herein, the applicability and suitability of such products for the intended purpose object shall be reviewed at the user responsibility.
- Although Sanken undertakes to enhance the quality and reliability of its products, the occurrence of failure and defect of semiconductor products at a certain rate is inevitable. Users of Sanken products are requested to take, at their own risk, preventative measures including safety design of the equipment or systems against any possible injury, death fires of or damages to the society due to device failure or malfunction.
- Sanken products listed in document are designed and intended for the use as components in general purpose electronic equipment or apparatus (home appliances, office equipment, telecommunication equipment, measuring equipment, etc.). Please sign this document prior to the use of the products herein. When considering the use of Sanken products in the applications where higher reliability is required (transportation equipment, and its control systems, traffic signal control systems or equipment, fire / crime alarm systems, various safety devices, etc.), please contact your nearest Sanken sales representative to discuss, and then sign this document prior to the use of the products herein. The use of Sanken products without the written consent of Sanken in the applications where extremely high reliability is required (aerospace equipment, nuclear power control systems, life support systems, etc.) is strictly prohibited.
- Anti radioactive ray design is not considered for the products listed herein.
- The contents of this brochure document shall not be transcribed nor copied without our written consent.